



SANDVIK LS312 FLAMEPROOF UNDERGROUND LOADER

PRODUCT LEAFLET



THE MECHANICS OF MINING MORE OUR NEW SANDVIK LS312

Our upgraded Sandvik LS312 flameproof underground loader is an enhanced 12 tonne high-capacity and heavy-duty loader powered by the C7.1 mechanical engine with Tier II emission standards.

The new engine development has targeted minimisation of emissions, maintenance and total costs of the Sandvik LS312.

This new LHD utility vehicle with Sandvik quick detachment system (QDS) provides an efficient and safe solution to meet the challenges of underground coal loading and hauling applications.

Furthermore it can be used in conjunction with our 57 tonne hydraulic assist roof support trailer for relocating larger longwall equipment.

The Sandvik LS312 is designed to meet the requirements of major international safety standards, including effective safety shutdown systems. Canopies for roll-over protection (ROPS) and against falling objects (FOPS) are standard as on all of our units.

Our upgraded Sandvik LS312 flameproof underground loader is full of new innovations which improve safety, minimise emissions, increase productivity, and lower your operating costs.

TECHNICAL DATA

Machine model	SANDVIK LS312
ENGINE	Caterpillar C7.1
Output	162 kW @2200 rpm
Torque	932 Nm @1400 rpm
Emission standard	Tier II
CAPACITIES	
Payload on forks	12,000 kg
Payload in bucket	10,700 kg
Standard bucket	3.1 m ³
Optional buckets	4.0m ³ stone bucket
SPEEDS FORWARD & REVERSE (LEVEL/LOADED)	
1st gear	4.4 km/h
2nd gear	9.0 km/h
3rd gear	15.5 km/h
4th gear	25.5 km/h
BUCKET MOTION TIMES	
Raising time	7 sec
Lowering time	5 sec
Dumping time	6 sec
OPERATING WEIGHTS	
Unladen weight	22,000 kg
Laden weight	35,000 kg
LADEN GROUND PRESSURES	
Loader end	1,011 kPa
Power module	305 kPa

THE MECHANICS OF IMPROVED SAFETY

- ✓ Reduced personnel exposure to harmful diesel emissions through use of Tier II engine and exhaust treatment systems
- ✓ SIL 1 electronic shutdown system available to ensure safe operation of explosion protected diesel engine system (DES)
- ✓ Improved operator visibility and operator ergonomics
- ✓ Ground level servicing with no requirement to access top of the machine to reach service points
- ✓ Proximity detection ready

THE MECHANICS OF MINIMISED EMISSIONS

- ✓ New C7.1 Tier II engine for lower diesel emissions
- ✓ Passive diesel exhaust filter for reduced diesel exhaust emissions
- ✓ Sandvik automatic fire suppression system

THE MECHANICS OF HIGHER PRODUCTIVITY

- ✓ Reduced maintenance time for maximized machine availability
- ✓ Increased engine performance with additional 20% torque and 8% power

THE MECHANICS OF LOWER OPERATING COSTS

- ✓ Lower operating costs through reduced consumables and 20% diesel fuel savings
- ✓ 15% reduction in engine service time due to reduced maintenance time
- ✓ Reduction in exhaust filter cost
- ✓ Digitalisation - productivity data: optimisation of machine utilisation and maintenance through analysis of operation data



KEY COMPONENTS AND FUNCTIONS OF SANDVIK LS312

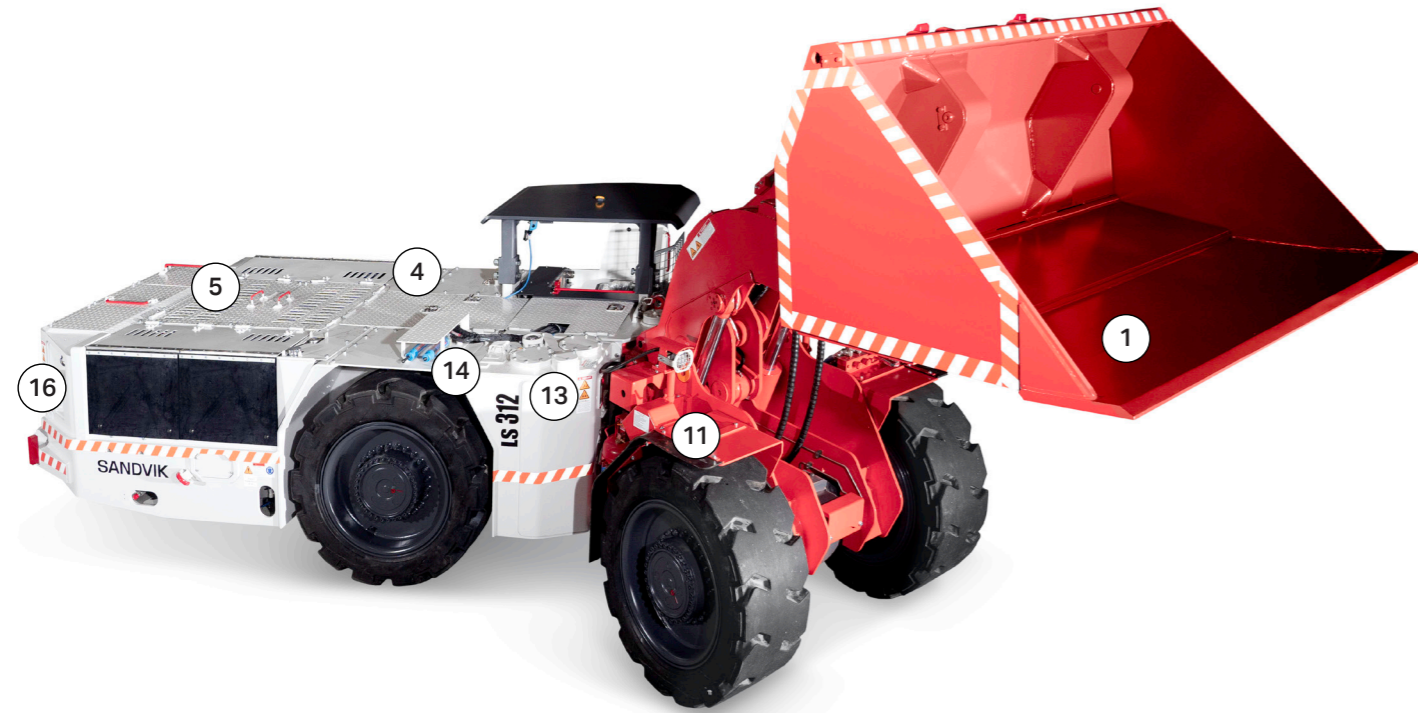

- ① Ejector bucket
- ② Front frame
- ③ Lift and tilt cylinders
- ④ Rear frame
- ⑤ Engine bay with covers
- ⑥ ROPS and FOPS canopy
- ⑦ Operator cabin
- ⑧ Wheels
- ⑨ Axle and brake hub
- ⑩ Quick detachment system (QDS) available for various purposes and functions
- ⑪ Power fill hydraulic oil fill pump
- ⑫ Upgraded pin design
- ⑬ Hydraulic tank
- ⑭ Transmission and torque converter
- ⑮ Tow hitch
- ⑯ Flameproof LED lights
- ⑰ Rear frame

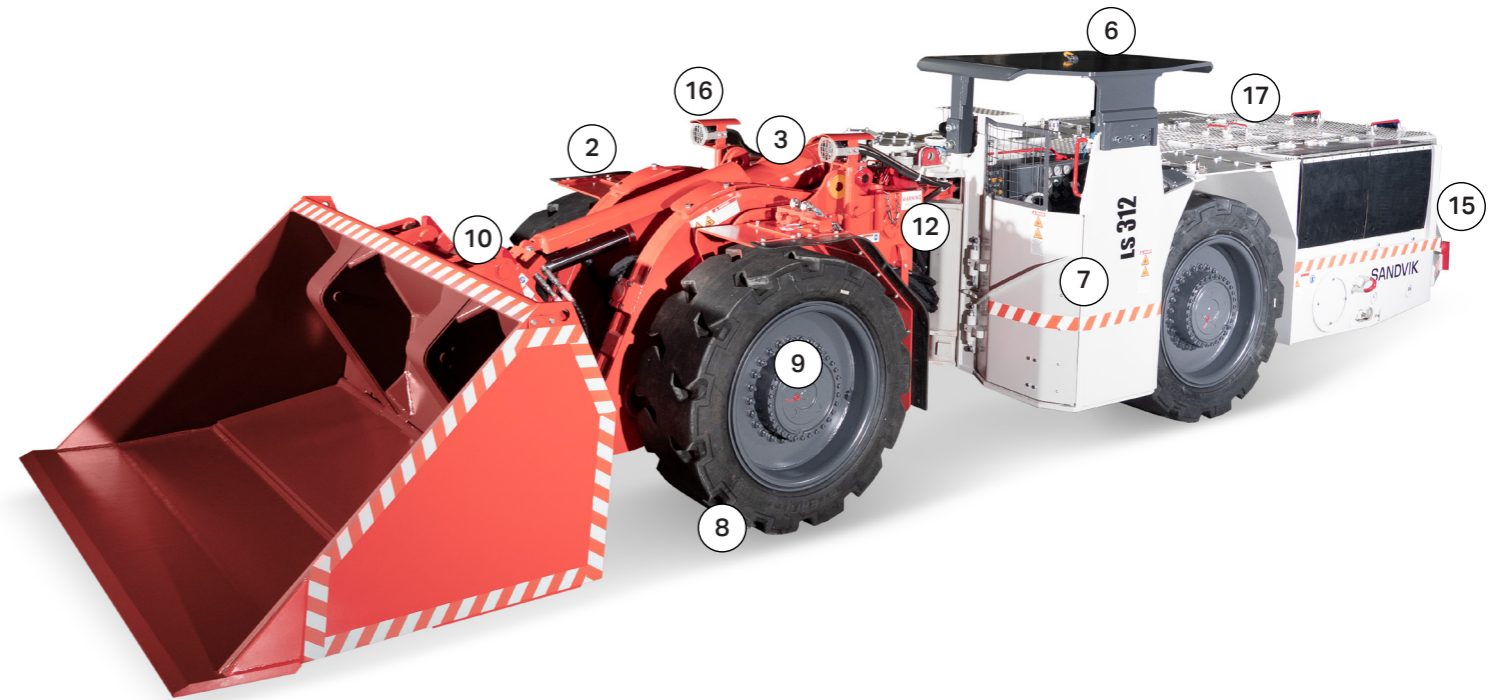
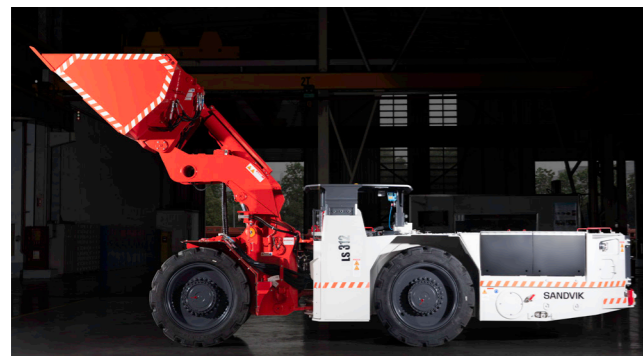

DIMENSIONS OF SANDVIK LS312

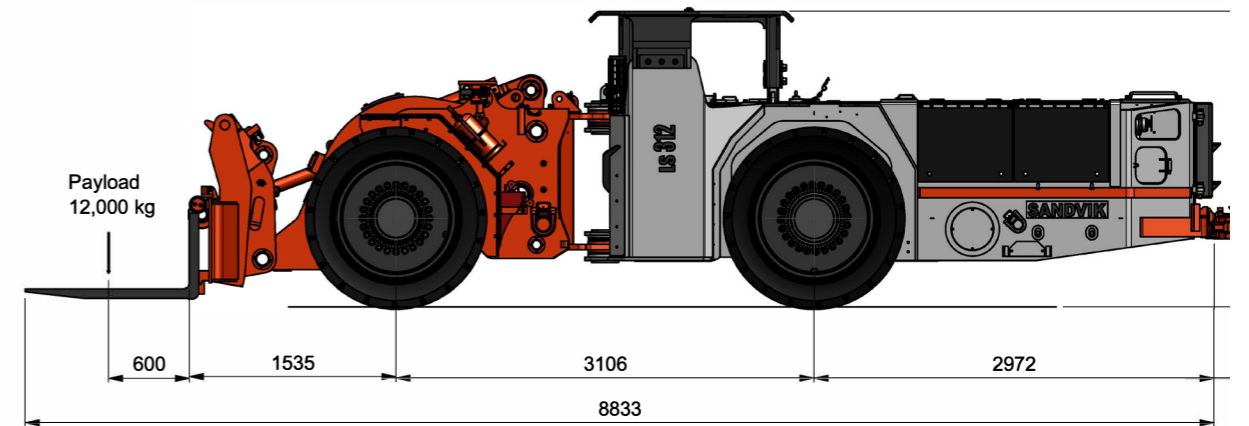
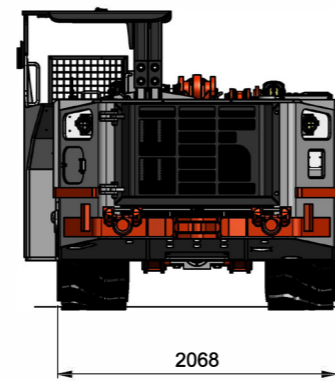
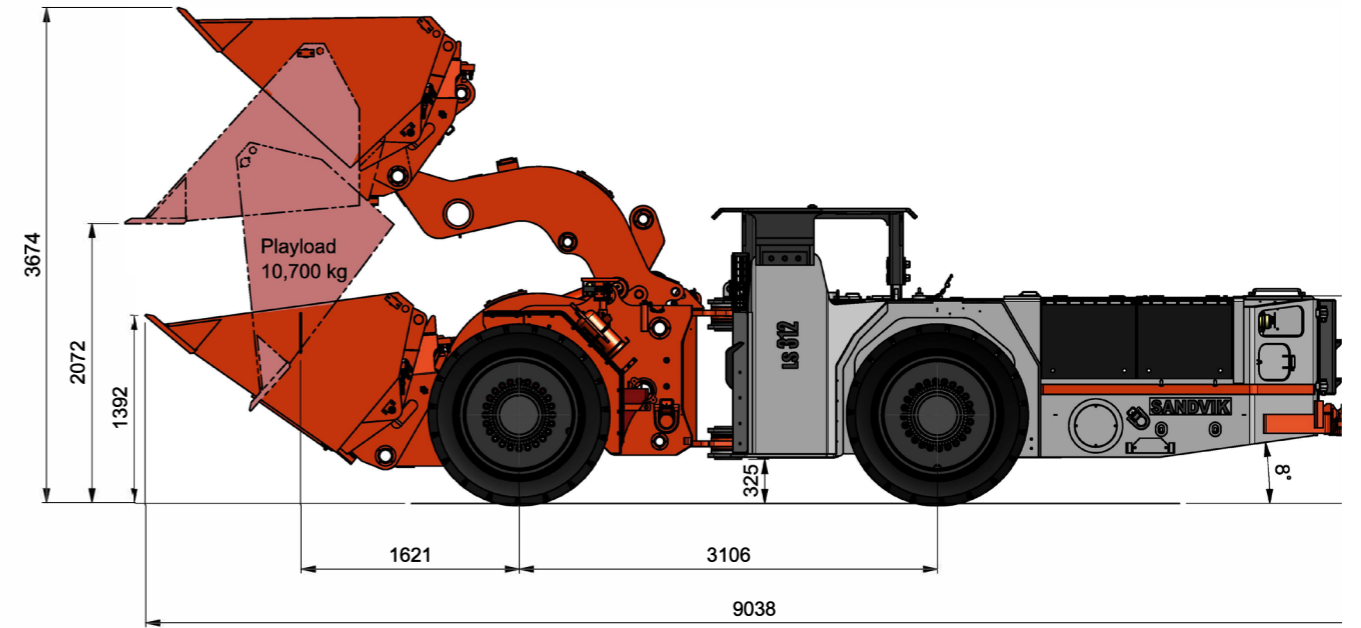
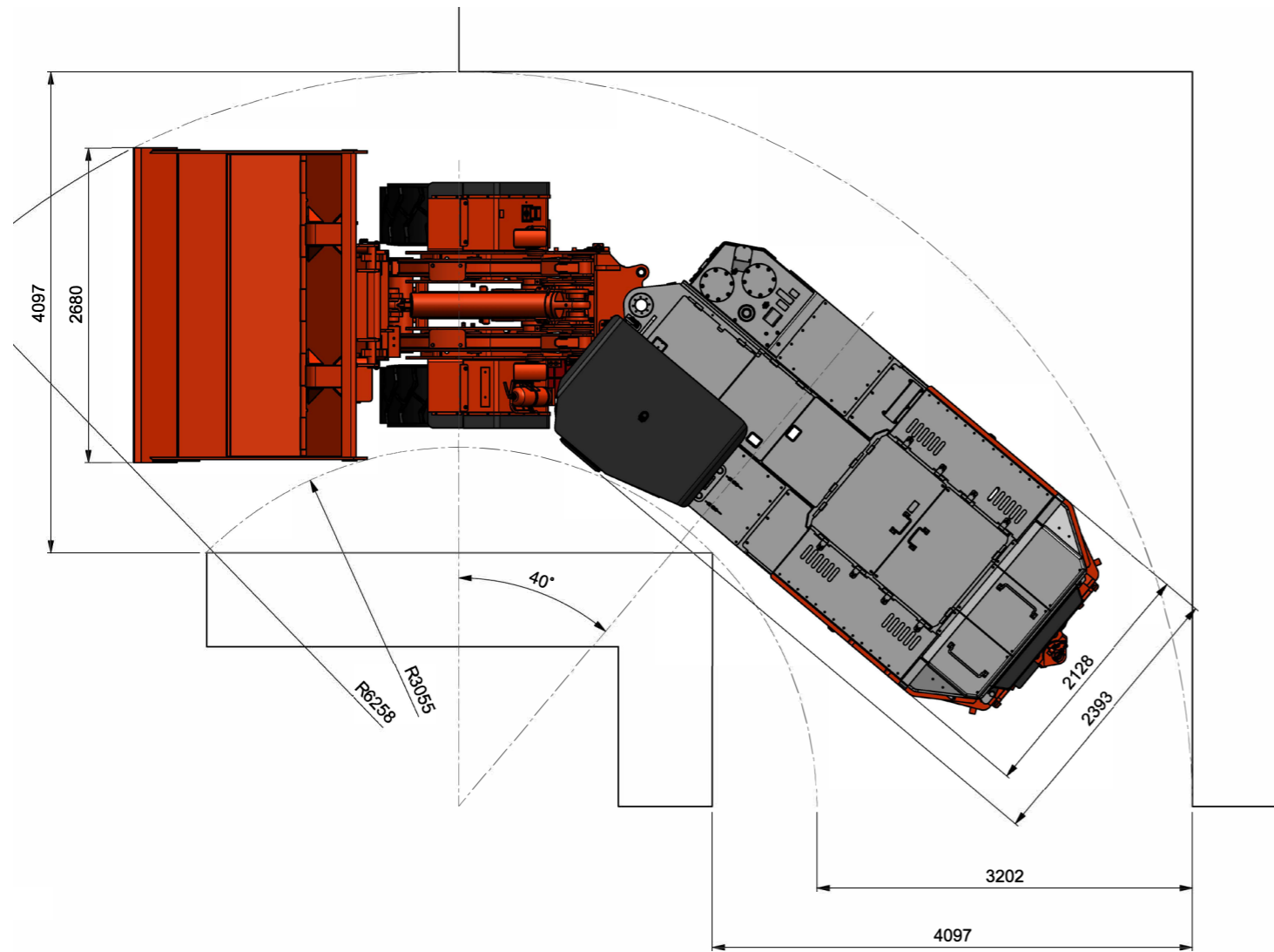

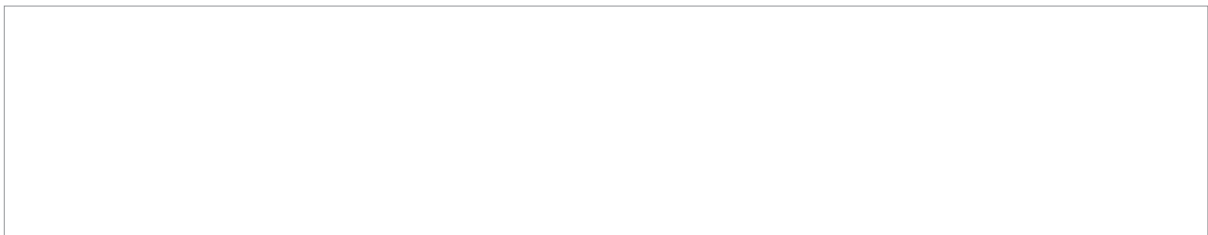

Sandvik reserves the right to make changes to the information on this data sheet without prior notification to users.
Please contact a Sandvik representative for clarification on specifications and options.