



TOP HAMMER ROCK DRILLING TOOLS

2022 / DIGITAL VERSION Q4



HEALTH AND SAFETY INFORMATION

ROUTES OF EXPOSURE

Grinding or heating hardmetal blanks or hardmetal products will produce dust or fumes with dangerous ingredients that can be inhaled or swallowed, or which might come in contact with the skin or eyes.

ACUTE TOXICITY

The dust is toxic by inhalation. Inhalation may cause irritation and inflammation in the airways. Skin contact can cause irritation and rash. Sensitive people may experience an allergic reaction.

CHRONIC TOXICITY

Repeated inhalation of aerosols containing cobalt may cause obstruction in the airways. Prolonged inhalation of increased concentrations may cause lung fibrosis or lung cancer. Cobalt is a potent skin sensitizer. Repeated or prolonged contact can cause sensitization.

CLASSIFICATION

Following hazard classification according to GHS/CLP applies to the hardmetal powder (3 % ≤ Co < 10 %):

- Acute Inhalation 3, H331: Toxic if inhaled
- Carcinogenicity 1B, H350i, May cause cancer by inhalation
- Repr. 2, H361f; Suspected of damaging fertility
- STOT RE 1, H372: Causes damage to lungs through prolonged or repeated exposure through inhalation
- Resp. Sens. 1B, H334 : May cause allergy or asthma symptoms or breathing difficulties if inhaled
- Skin Sens.1, H317: May cause an allergic skin reaction.
- Aquatic Acute 1, H400: Very toxic to aquatic life
- Aquatic Chronic 2, H411: Toxic to aquatic life, with long lasting effects.

PRECAUTIONARY STATEMENTS

- Do not breathe the dust
- Wear protective gloves/protective clothing/eye protection
- In case of inadequate ventilation, wear respiratory protection
- Avoid release into the environment

IF INHALED: If breathing is difficult, remove the victim to fresh air and keep them at rest in a position comfortable for breathing. If they are experiencing respiratory symptoms: Call a POISON CENTER or doctor/physician.

ROTATING PARTS

Shank adapters, rods and bits are rotating parts and can cause severe injury. Stay away while drill rig is in operation. Do not change bit during rotation as you can get stuck and severely injured.

DISASSEMBLY OF HOT BIT, ROD, COUPLING, SLEEVE, SHANKADAPTER AND INTEGRAL STEEL

- Ensure that products have cooled down before disassembling
- Never work on hot parts
- Consider the appropriate hand protection (gloves) for the handling of warm parts

CHANGING BITS

Do not use a sledge hammer or similar to loosen bits as steel parts may detach and cause severe damage on body parts. Instead use appropriate tools such as knock-off tools or wrenches.

CLEANING OF RODS

A particular hazard exists with cleaning rods if the rods contain explosives. Sandvik rock tools should never be used in a hole that has been filled with explosives.

DEALING WITH WORN PARTS

Worn parts should be removed and disposed appropriately. Consider recycling any used drill bits. Please contact your local Sandvik representative for support and further information regarding the recycling process.

HANDLING OF HEAVY TOOLS

Lifting heavy items is one of the leading causes of injury, ie strain and crushing body parts in workplaces. Be aware that many of our tools are heavy and take the needed actions before any manual handling is done to prevent injuries.

STORING

All products should be stored in a dry place and in their original packaging until they are required for use.

GENERAL

The products in this catalog are designed for drilling holes in rock, and should only be used for this purpose.

SANDVIK ROCK TOOLS: A SUSTAINABLE CHOICE

Sandvik is committed to contributing to a sustainable world. This commitment is summarized by our sustainability agenda for 2030 with goals in four areas: "Make the Shift".

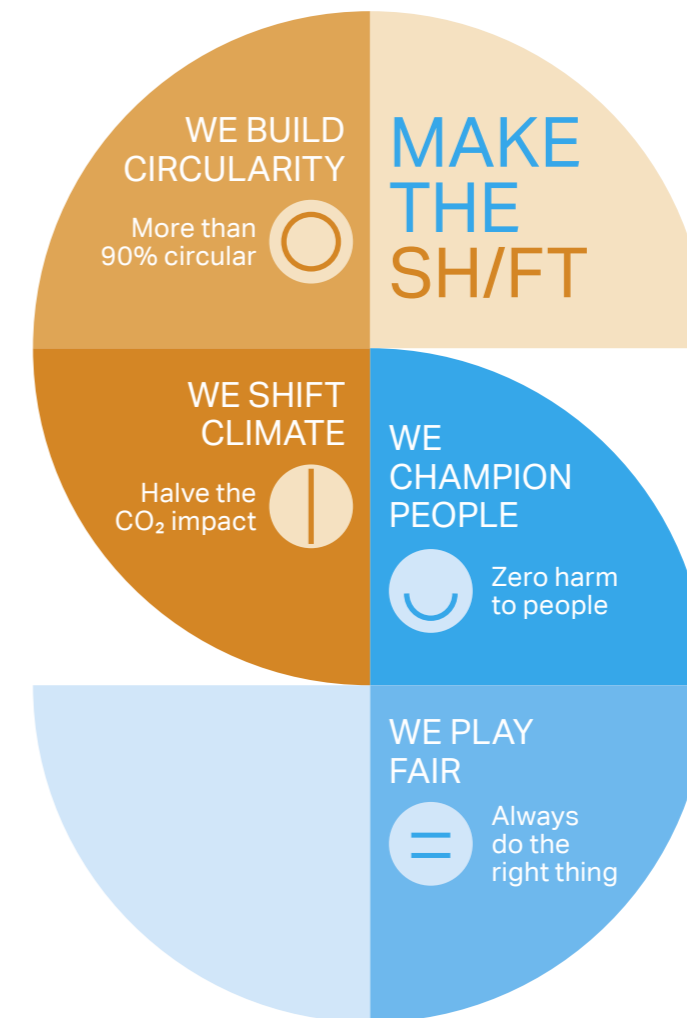

GLOBAL CARBIDE RECYCLING

Sandvik Rock Tools is world-leading in recycling cemented carbide. We view our customers' waste problem as an opportunity. By finding ways to make our own and our customers' businesses more energy efficient and environmentally friendly, we can grow together with high ethics and brand recognition.

The benefits are great with making tools from recycled solid carbide:

- 70% less energy
- 40% less CO₂ emissions

OPTIMIZED LOGISTICS CHAIN

Sandvik Rock Tools work closely with both customers and suppliers to optimize the entire logistics chain in order to reduce our global footprint. Between 2017 and 2019, Sandvik Rock Tools reduced its airfreight with 140%, and in all transportation we have reduced the CO₂ emissions with more than 33%!



CONTENTS

HANDHELD AND SMALL HOLE DRILLING	9
FACE DRILLING AND BOLTING	21
BENCH DRILLING	39
LONG-HOLE DRILLING UNDERGROUND	55
SHANK ADAPTERS	69
AUXILIARY TOOLS	87
INFORMATION AND BIT CLASSIFICATION GUIDE	90
GRINDING EQUIPMENT	95
NOTES	114



RECYCLING THAT PAYS OFF FOR YOU

Environmental considerations are crucial in all of our operations, and never more so than when it comes to the recycling of cemented carbide.

The global shortage of raw material has inspired us to create an extensive scrap-recycling program. We recognize today's increasing environmental concerns, and we are the only mining company that recycles both steel and cemented carbide.

In fact, we have been collecting and recycling both scrap and discarded drilling consumables for conversion back into basic raw materials for almost 10 years. A large number of customers have joined our recycling program during this period. One major reason for this is that we make it easy for them to recycle, by collecting scrap from their own premises.

All of our customer service centres are now set up to receive used cemented carbide-enhanced products. Our recycling plant in Chiplun, India complies with the most stringent environmental standards, and is certified to the ISO 14001 and OHSAS 18001 (ISO 45001) international standard.

WHAT WE OFFER:

- Recycling of cemented carbide available worldwide
- Sustainable recycling process with low environmental impact
- Cost recovery and reduced waste disposal for you
- Money received for worn tools can purchase new inserts or finance new tooling projects

- Consumables and tools from all manufacturers are accepted
- A win-win situation for all

Adopting sustainable business practices and handling them in the right way is a foundation that contributes across the entire business value chain.

The whole supply chain will be improved by incorporating recycling into the business process. For instance, our recycling process significantly reduces energy consumption and carbon dioxide emissions, thereby reducing environmental impact.

CARBIDE RECYCLING PROGRAM PART OF SANDVIK SUSTAINABLE BUSINESS

PRESERVE OUR PLANET

The global shortage of raw materials has inspired our scrap recycling program, the program addresses today's increasing environmental concerns.

We recycle your used Carbide Enhanced Rock Tools as easy as possible with a convenient collection at your operation. We'll pay market price for the Carbide and recycle it to create new tools.

Together with our customers, we'll reduce the environmental impacts of Rock Tools production.

IT'S THE INSIDE THAT MATTERS TO THE BOTTOM LINE

PowerCarbide™ is a gathering of our most powerful carbide grades. With its outstanding performance PowerCarbide™ improves your results. In your drilling operation as well as in your business.



THE SANDVIK POWERCARBIDE™ GRADES

DUAL PROPERTY GRADES

DP55 has wear resistance similar to our standard grades, but offers greater toughness. It is especially suited to large ballistic inserts, accommodating the higher loads the insert may be exposed to due to a longer protrusion. DP65 has similar toughness to our standard grades, but a considerably higher wear resistance. This grade works best when drilling in very abrasive rock with large spherical inserts.

GRADIENT CARBIDE GRADES

GC80 and GC81 is developed for hard and abrasive ground conditions. Our innovative manufacturing process makes it possible to produce buttons that are wear-resistant on the outside, while the center provides a toughness that further extends service life and grinding intervals.

SELF HARDENING GRADES

SH70 is a grade with homogeneous properties throughout the material. It is "self-hardening" as it has the ability to become both more wear resistant and tougher as drilling progresses.

The hardness of the insert surface continuously increases during drilling, which means that the hard top never wears off. The self-hardening effect is greatest in hard and competent ground.

XT49

XT49 takes the standard straight grade XT48 to the next level. Our manufacturing process enables the reduction of early breakages of the insert. As this grade is more resilient to breakage, it enables more protrusion and a sharper geometry.

ROCK TOOLS DIFFERENT INSERT TYPES

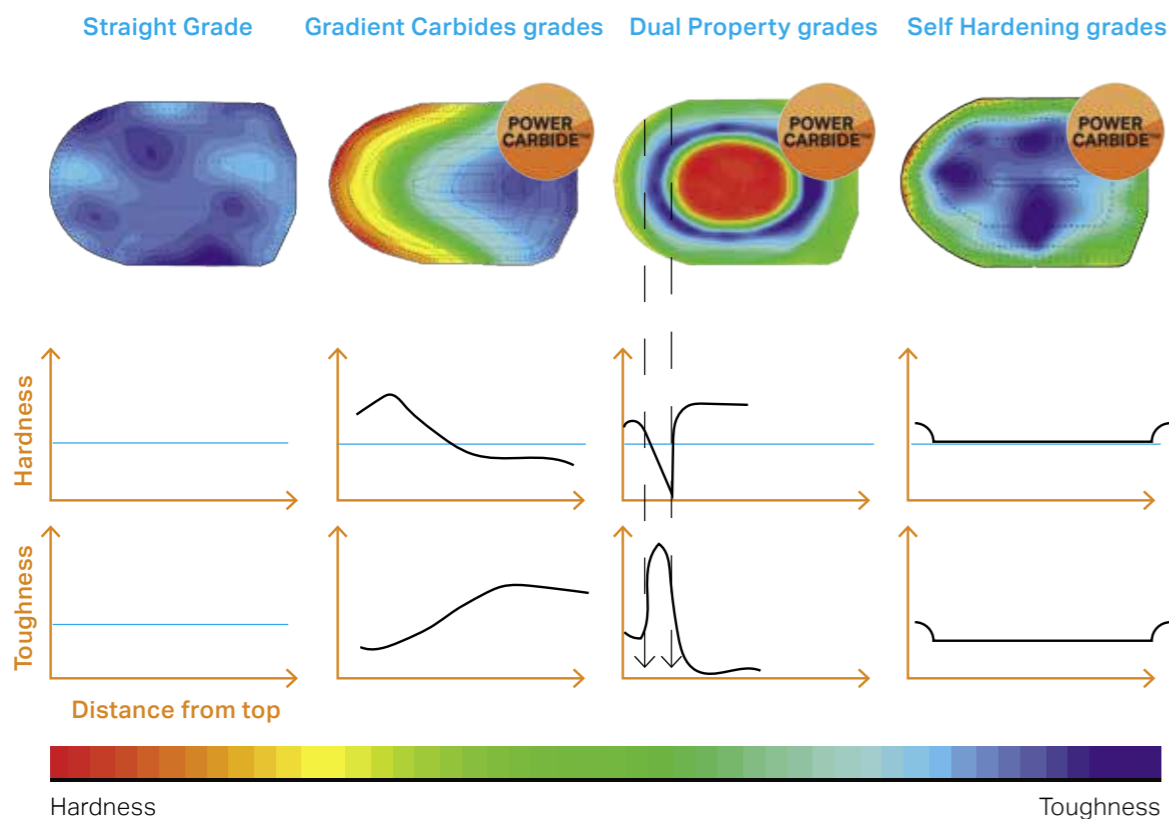

*The images above show a cross-section of our different insert types

EXTEND SERVICE LIFE INCREASE PRODUCTIVITY

Integral drill steels, tapered rods, drill bits and threaded rods are crucial for peak productivity in all applications. Our drill steel has a high fatigue strength and toughness, and offers the high wear resistance that ensures an efficient and economic drilling operation. The unique Sandvik R23 rods and bits for extension drilling provide the strongest thread in

sizes ranging from 33 to 45 mm. For underground applications, we have fully carburized rods with superior wear resistance and service life. When you partner with Sandvik, you can expect consistently high quality and maximum operational dependability when it comes to all small hole drilling applications.

H22 (7/8") INTEGRAL DRILL STEELS	10
H22 TAPERED TOOLS, 12° TAPER	11
H22 TAPERED TOOLS, 11° TAPER	13
H22 TAPERED TOOLS, 7° TAPER	14
RR23 (29/32") EXTENSION DRILLING TOOLS	15
R25 (1") EXTENSION DRILLING TOOLS	16
R28 (1 1/8") EXTENSION DRILLING TOOLS	18
TOOL SELECTION	19

HANDHELD AND SMALL HOLE DRILLING





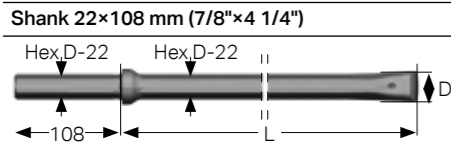

H22 (7/8") INTEGRAL DRILL STEELS

Series	DIMENSIONS				PART NO.	
	L mm	ft	in	D mm	in	
Shank 22x108 mm (7/8"x4 1/4")						
11	800	2'	7"	34	1 11/32"	714-0834-65
	1600	5'	3"	33	1 19/64"	714-1633-65
	2400	7'	10"	32	1 1/4"	714-2432-65
	3200	10'	6"	31	1 7/32"	714-3231
	4000	13'	1"	30	1 3/16"	714-4030
	4800	15'	9"	29	1 9/64"	714-4829
	5600	18'	4"	28	1 7/64"	714-5628-50
	6400	21'	-	27	1 1/16"	714-6427-50
	7200	23'	8"	26	1 1/32"	714-7226-50
	12	800	2'	7"	40	1 37/64"
1600		5'	3"	39	1 17/32"	714-1639-65
2400		7'	10"	38	1 1/2"	714-2438-65
3200		10'	6"	37	1 29/64"	714-3237-65
4000		13'	1"	36	1 27/64"	714-4036-65
4800		15'	9"	35	1 3/8"	714-4835-65
5600		18'	4"	34	1 11/32"	714-5634-65
6400		21'	-	33	1 19/64"	714-6433-65
7200		23'	8"	32	1 1/4"	714-7232-65
13		400	1'	4"	34	1 11/32"
	800	2'	7"	33	1 19/64"	714-0833-65
	1200	3'	11"	32	1 1/4"	714-1232-65
	2000	6'	7"	30	1 3/16"	714-2030
16	600	2'	-	35	1 3/8"	714-0635-65
	1200	3'	11"	34	1 11/32"	714-1234-65
	1800	5'	11"	33	1 19/64"	714-1833-65
	2400	7'	10"	32	1 1/4"	714-2432-65
17	600	2'	-	41	1 5/8"	714-0641-65
	1200	3'	11"	40	1 37/64"	714-1240-65
	1800	5'	11"	39	1 17/32"	714-1839-65
	2400	7'	10"	38	1 1/2"	714-2438-65
	2000	6'	7"	33	1 19/64"	714-2033-65
	8000	26'	3"	26	1 1/32"	714-8026-50
8800	28'	11"	25	1"	714-8825-5005	
9600	31'	6"	25	1"	714-9625-5005	
1600	5'	3"	28	1 7/64"	714-1628-50	
2400	7'	10"	27	1 1/16"	714-2427-50	



HANDHELD AND SMALL HOLE DRILLING

H22 TAPERED TOOLS, 12° TAPER

BITS	FLUSHING HOLE, MM		BUTTONS, MM		ANGLE	DIMENSIONS D		BIT CLASSIFICATION	PART NO.
	Front No	Gauge Size	Front No	Gauge Size		mm	in		
Button bit 	1x5	1x5	1x7	4x7	35°	28	1 1/8"	●	7795-6428-B48
	1x5	1x5	1x7	4x7	35°	30	1 3/16"	●	7795-6430-B48
Button bit 	2x4	1x4	2x7	5x7	40°	32	1 1/4"	●	7795-5232-B48
	2x4	1x4	2x7	5x8	40°	35	1 3/8"	●	7795-5235-B48
	2x5	1x5	2x7	5x9	40°	38	1 1/2"	●	7795-5238-B48
Button bit 	2x4	1x4	2x7	5x7	40°	33	1 9/64"	●	7770-5233-B48
	2x4	1x4	2x7	5x8	40°	35	1 3/8"	●	7770-5235-B48
Button bit 	1x4	1x6	2x7	5x7	35°	33	1 9/64"	●	7770-4433-B48
Button bit 	2x4	1x4	2x7	6x7	40°	33	1 9/64"	●	7770-5433-B48
	2x4	1x4	2x7	6x8	40°	35	1 3/8"	●	7770-5435-B48
Button bit 	2x4	1x5	2x7	6x7	40°	33	1 9/64"	●	5770-5433M-B49
	2x4	1x5	2x7	6x8	40°	33	1 9/64"	●	5770-5433M-B70
Cross bit 	1x6	2x4.5	-	-	-	32	1 1/4"	●	7770-9032-42
	1x6.35	2x4.5	-	-	-	45	1 3/8"	●	7770-9045-42

BIT DIAMETER NOTES

All bit diameters are larger than the given dimensions in the catalog.

Cross bits: Can be a maximum of +1 mm due to manufacturing tolerance.

Button bits: Some bit designs can be a maximum +3 mm to compensate for fast diameter wear. The minimum diameter for all button bits is +1.5 mm above the given dimensions.

Keep in mind that a bit always drills a bigger hole than the stated bit diameter.

HANDHELD AND SMALL HOLE DRILLING

H22 TAPERED TOOLS, 12° TAPER

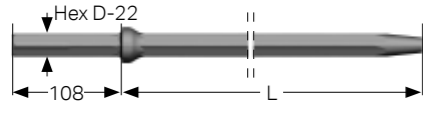
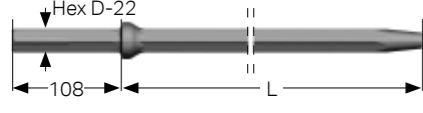
RODS	DIMENSIONS					PART NO.
	L mm	ft	in	D mm	in	
Tapered rod, shank 22×108, carburized						
	610	2'	-	22	7/8"	7870-6106-11
	1220	4'	-	22	7/8"	7870-6112-11
	1830	6'	-	22	7/8"	7870-6118-11
	2000	6'	7"	22	7/8"	7870-6120-11
	2440	8'	-	22	7/8"	7870-6124-11
	3050	10'	-	22	7/8"	7870-6131-11
	3200	10'	6"	22	7/8"	7870-6132-11
	3660	12'	-	22	7/8"	7870-6137-11
	4300	14'	1 1/2"	22	7/8"	7870-6143-11
Tapered rod, shank 22×108, HF-hardened – For surface drilling						
	2440	8'	-	22	7/8"	7870-1124-11
	3200	10'	6"	22	7/8"	7870-1132-11
	4000	13'	1 1/2"	22	7/8"	7870-1140-11
	4400	14'	5"	22	7/8"	7870-1144-11
	4800	15'	9"	22	7/8"	7870-1148-11
	5600	18'	4 1/2"	22	7/8"	7870-1156-11
	6400	21'	-	22	7/8"	7870-1164-11
	7200	23'	7 1/2"	22	7/8"	7870-1172-11
	8000	26'	3"	22	7/8"	7870-1180-11
8800	28'	10 1/2"	22	7/8"	7870-1188-11	

H25 TAPERED TOOLS 12° TAPER

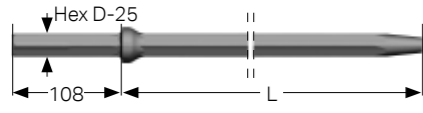
RODS	DIMENSIONS					PART NO.
	L mm	ft	in	D mm	in	
Tapered rod, shank 25X108, carburized						
	4300	14'	-	25	1"	7870-7143-30

HANDHELD AND SMALL HOLE DRILLING

H22 TAPERED TOOLS, 11° TAPER

BITS	FLUSHING HOLE, MM		BUTTONS, MM		ANGLE	DIMENSIONS D		BIT CLASSIFICATION	PART NO.
	Front No	Gauge Size	Front No	Gauge Size		mm	in		
Button bit									
	1×5	1×5	2×7	5×7	40°	32	1 1/4"	●	7776-4432-B48
	1×5	1×5	2×7	5×8	40°	35	1 3/8"	●	7776-4435-B48
	1×5	1×5	2×7	5×8	35°	36	1 7/16"	●	7776-4436-B48
	1×6	1×6	2×7	5×8	35°	38	1 1/2"	●	7776-4438-B48
	1×6	1×6	2×8	5×9	35°	40	1 37/64"	●	7776-4440-B48

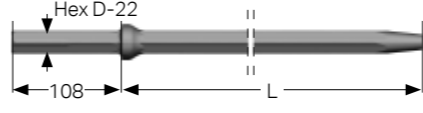
RODS	DIMENSIONS					PART NO.
	L mm	ft	in	D mm	in	
Tapered rod, shank 22×108, carburized						
	610	2'	-	22	7/8"	7876-6106-11
	800	2'	7 1/2"	22	7/8"	7876-6108-11
	1220	4'	-	22	7/8"	7876-6112-11
	1600	5'	3"	22	7/8"	7876-6116-11
	1830	6'	-	22	7/8"	7876-6118-11
	2000	6'	7"	22	7/8"	7876-6120-11
	2440	8'	-	22	7/8"	7876-6124-11
	3050	10'	-	22	7/8"	7876-6131-11
	3600	11'	9 1/2"	22	7/8"	7876-6136-11

HANDHELD AND SMALL HOLE DRILLING

H22 TAPERED TOOLS, 7° TAPER

BITS	FLUSHING HOLE, MM		BUTTONS, MM		ANGLE	DIMENSIONS D		BIT CLASSIFICATION	PART NO.
	Front No Size	Gauge No Size	Front No Size	Gauge No Size		mm	in		
 Button bit	2×5	1×5	2×7	5×7	40°	32	1 1/4"	●	7788-5232-B48
	2×4	1×4	2×7	5×7	40°	33	1 9/64"	●	7788-5233-B48
	2×4	1×4	2×7	5×8	40°	35	1 3/8"	●	7788-5235-B48
	2×4	1×4	2×7	5×8	35°	38	1 1/2"	●	7788-5238-B48

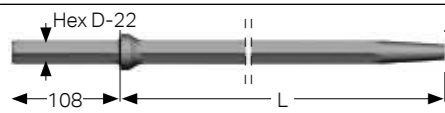
RODS	DIMENSIONS					PART NO.
	L mm	ft	in	D mm	in	
 Tapered rod, shank 22×108, carburized	2400	8'	-	22	7/8"	7888-6124-11
	3200	10'	6"	22	7/8"	7888-6132-11

HANDHELD AND SMALL HOLE DRILLING

R23 (29/32") EXTENSION DRILLING TOOLS

BITS	FLUSHING HOLE, MM		BUTTONS, MM		ANGLE	DIMENSIONS D		BIT CLASSIFICATION	PART NO.
	Front No Size	Gauge No Size	Front No Size	Gauge No Size		mm	in		
 Button bit	1×4	1×6	2×7	5×7	35°	33	1 5/16"	●	7737-4433-R48
	1×6	1×6	2×7	5×8	40°	35	1 3/8"	●	7737-5235-R48
	1×6	1×6	2×7	5×9	35°	38	1 1/2"	●	7737-5238A-R48
	1×6	1×6	2×8	5×9	35°	41	1 5/8"	●	7737-5241-R48
	3×4.5	-	3×8	6×9	40°	45	1 3/4"	●	7737-5345-R48

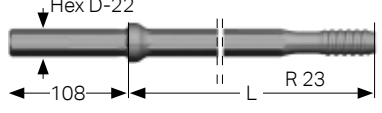
RODS	DIMENSIONS					PART NO.
	L mm	ft	in	D mm	in	
 Shank adapter / Shank rod, Hex 22 – R23	255	-	10 3/64"	22	7/8"	7807-6103-11
	800	2'	7"	22	7/8"	7807-6108-11
	1600	5'	3"	22	7/8"	7807-6116-11
	2400	8'	-	22	7/8"	7807-6124-11
	3200	10'	-	22	7/8"	7807-6132-11
	3600	11'	9 5/8"	22	7/8"	7807-6136-11

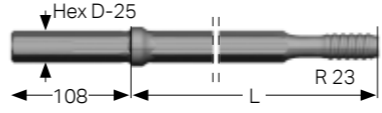

RODS	DIMENSIONS					PART NO.
	L mm	ft	in	D mm	in	
 MF-rod, R23 – Hex 22 – R23	2095	6'	10 1/2"	22	7/8"	7857-4821-20
	3050	10'	-	22	7/8"	7857-4831-20

Female end Ø 31 mm.

RODS	DIMENSIONS					PART NO.
	L mm	ft	in	D mm	in	
 Shank adapter / Shank rod, Hex 25 – R23	255	-	10 3/64"	25	1"	7807-7103-30



HANDHELD AND SMALL HOLE DRILLING

R25 (1") EXTENSION DRILLING TOOLS

BITS	FLUSHING HOLE, MM		BUTTONS, MM		ANGLE	DIMENSIONS D		BIT CLASSIFICATION	PART NO.
	Front No	Gauge No	Front No	Gauge No		mm	in		
	Size	Size	Size	Size					
Button bit, type 44/52									
	1x5	1x6	2x7	5x7	45°	33	1 5/16"	●	7732-4433C-S48
	1x4	1x6	2x7	5x9	30°	35	1 3/8"	●	7732-4435-S48
	1x4	1x6	2x7	5x9	30°	35	1 3/8"	●	7732-4435-S70
	1x4	1x6	2x7	5x9	30°	35	1 3/8"	●	7732-4435-S80
	1x5	1x6	2x7	5x9	30°	37	7/16"	●	7732-4437C-S48
	1x6	1x6	2x7	5x8	40°	35	1 3/8"	●	7732-5235-R48
	1x6	1x6	2x7	5x9	35°	38	1 1/2"	●	7732-5238-R48
	1x6	1x6	2x7	5x9	35°	38	1 1/2"	●	7732-5238-S48
	1x6	1x6	2x7	5x9	35°	41	1 5/8"	●	7732-5241-S48
	Button bit, type 53								
	3x4.5	-	3x8	6x9	40°	45	1 3/4"	●	7732-5345F-R48
	3x4.5	1x4.5	3x8	6x10	30°	48	1 7/8"	●	7732-5348A-S48
Cross bit									
	1x5	2x5				35	1 3/8"	●	7732-1435-42

HANDHELD AND SMALL HOLE DRILLING

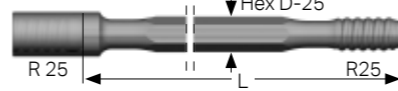
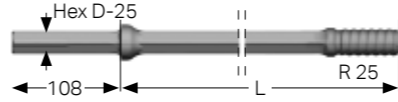
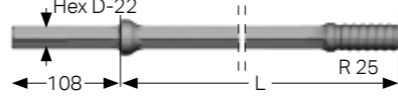
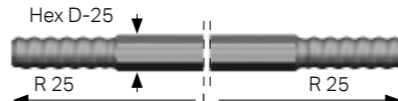
R25 (1") EXTENSION DRILLING TOOLS

RODS	DIMENSIONS					PART NO.
	L	ft	in	D		
				mm	in	
MF-ROD, R25 – Hex 25 – R 25						
	1220	4'	-	25	1"	7852-3112-20
	3025	10'	-	25	1"	7852-313025-20
	3660	12'	-	25	1"	7852-3137-20
Shank adapter / Shank rod, Hex 25 x R25						
	2400	7'	10"	25	1"	7802-7124-30
	3735	12'	3"	25	1"	7802-71373-30
Shank adapter / Shank rod, Hex 22 x R25						
	255	-	10 3/64"	22	7/8"	7802-6103-11
	800	2'	7"	22	7/8"	7802-6108-11
	1000	3'	3"	22	7/8"	7802-6110-11
Extension rod, R25 – Hex 25 – R25						
	915	3'	-	25	1"	7852-2309-20
	1220	4'	-	25	1"	7852-2312-20
	1525	5'	-	25	1"	7852-2315-20
	1830	6'	-	25	1"	7852-2318-20
	2435	8'	-	25	1"	7852-2324-20
	3050	10'	-	25	1"	7852-2331-20
Coupling sleeve, R25						
	160	-	6 1/4"	35	1 3/8"	7992-3335

HANDHELD AND SMALL HOLE DRILLING

R28 (1 1/8") EXTENSION DRILLING TOOLS

BITS	FLUSHING HOLE, MM		BUTTONS, MM		ANGLE	DIMENSIONS D		BIT CLASSIFICATION	PART NO.
	Front No Size	Gauge No Size	Front No Size	Gauge No Size		mm	in		
 Button bit, type 52	1×5	1×6	2×7	5×9	30°	37	7/16"	●	7739-5237-S48
	1×6	1×6	2×7	5×9	35°	38	1 1/2"	○	7739-5238-R48
	1×6	1×6	2×7	5×9	35°	38	1 1/2"	●	7739-5238-S48
	1×6	1×6	2×7	5×9	35°	38	1 1/2"	●	7739-5238-S70
	1×6	1×6	2×7	5×9	35°	38	1 1/2"	●	7739-5238-S80
	1×6	1×6	2×8	5×9	35°	41	1 5/8"	●	7739-5241-S48
	1×6	1×6	2×8	5×10	35°	43	1 11/16"	●	7739-5243-S48

REAMING TOOLS	THREAD	DIMENSIONS					PART NO.
		L mm	ft	in	D mm	in	
Reaming tools for cut holes / Pilot adapter, 6° taper	R28	285	-	11 1/4"	26	1 1/32"	7822-1526

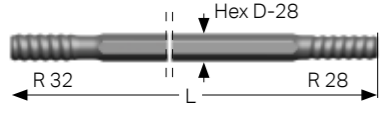

REAMING TOOLS FOR CUT HOLES / REAMING BIT, 6° TAPER	BUTTONS, MM		ANGLE	DIMENSIONS D		PART NO.
	Front No Size	Gauge No Size		mm	in	
 Reaming tools for cut holes / Reaming bit, 6° taper	4×8	8×9	25°	64	2 1/2"	7722-4864-S48
	4×10	8×10	30°	76	3"	7722-4876-S48
	6×10	8×12	35°	89	3 1/2"	7722-4889-S48

RODS	DIMENSIONS					PART NO.
	L mm	ft	in	D mm	in	
 Drifter rod, R32 - Hex 28 - R28	2475	8'	1 1/2"	28	1 1/8"	7853-7624-20
	2785	9'	1 5/8"	28	1 1/8"	7853-7627-20
	3090	10'	1 5/8"	28	1 1/8"	7853-7631-20
	3340	10'	11 1/2"	28	1 1/8"	7853-7633-20
	3700	12'	1 5/8"	28	1 1/8"	7853-7637-20
	4305	14'	1 1/2"	28	1 1/8"	7853-7643-20

Flushing hole Ø 8.8 mm.

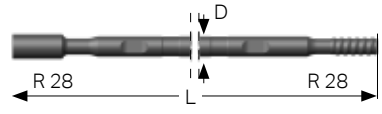
 MF-rod, R28 - Round 32 - R28	3050	10'	-	32	1 1/1"	7859-5131-20
	3660	12'	-	32	1 1/1"	7859-5137-20

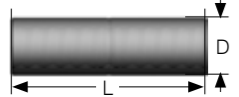
 Coupling sleeve, R32	150		5 29/32"	44	1 47/64"	7993-3644
---	-----	--	----------	----	----------	-----------

TOOL SELECTION

SANDVIK TOOL SELECTION FOR SMALL HOLE DRILLING



DESIGN 19

Designed for short holes < 2 m, these low-pressure hammers are ideal for solid rock formations.



DESIGN 44/52

This premium, wear resistant bit features a strong gauge and is designed to be a strong performer in all rock conditions. The high-pressure hammers are specifically made to achieve high penetration rates.



DESIGN 54

With this premium bit, designed for high wear resistance in all rock conditions – featuring a strong gauge – you can get the most out of your operations. The high-pressure hammers also deliver quick penetration rates.

ALWAYS IMPROVING YOUR SOLUTIONS

Our engineers are continuously engaged in upgrading our tool systems. Supported by our in-house manufacturing facilities, they engineer solutions that enable you and other rock-drilling professionals around the world to work even more profitably with the latest technology.

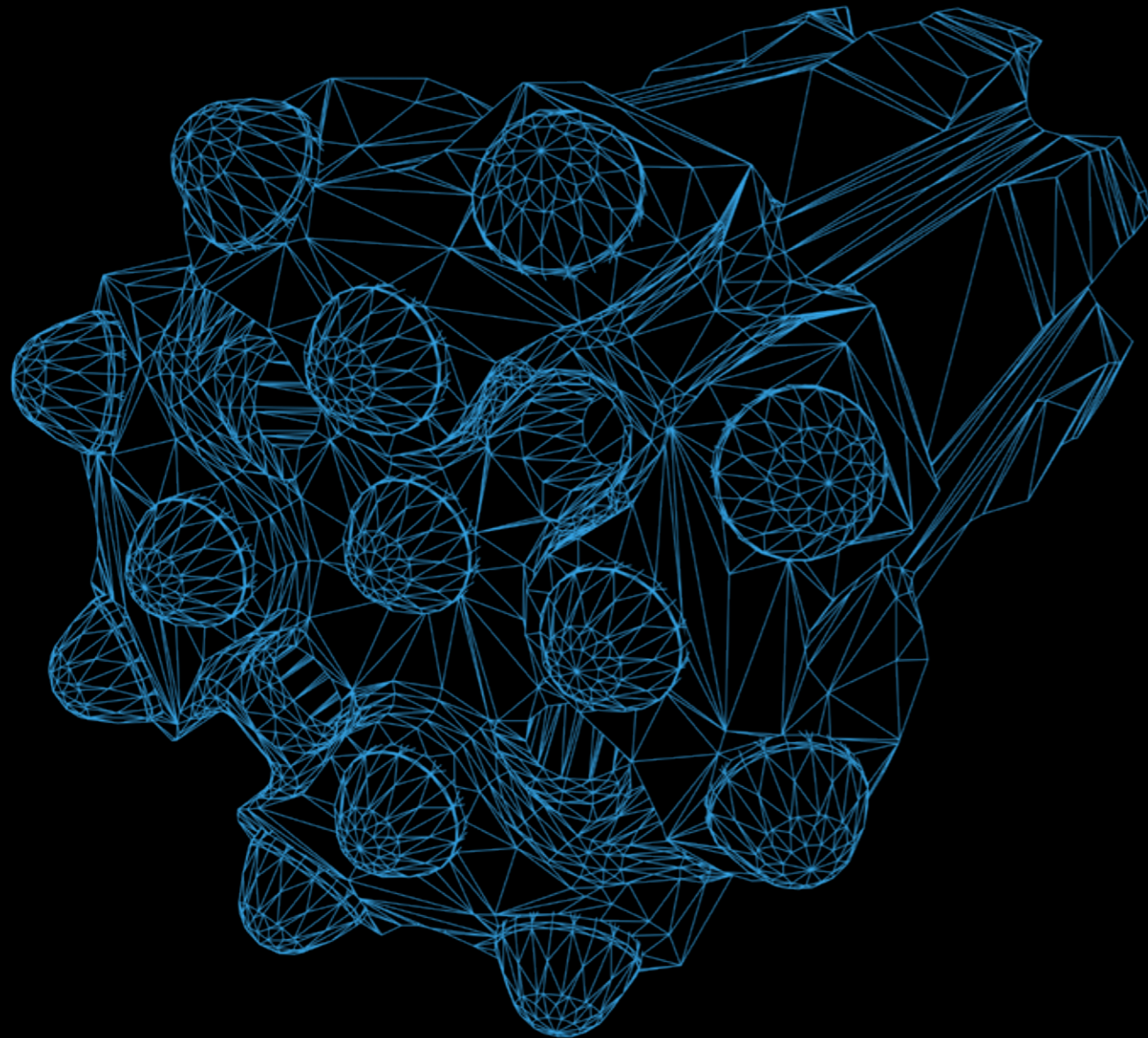

R25 (1") BIT THREAD	24
R28 (1 1/8") BIT THREAD	26
R32 (1 1/4") BIT THREAD	27
SANDVIK ALPHA™. α330 BIT THREAD	30
R35 (1 3/8") BIT THREAD	33
SANDVIK GT38	35
SANDVIK DRIFTER BITS	36



STRAIGHTER HOLES AND IMPROVED PERFORMANCE

Sandvik Alpha™ is a market-leading drill system for both tunneling and mine development applications. The benefits of using it are great: you can reduce your rock tools costs with up to 20%, and at the same time achieve more efficient drilling operations compared to standard systems.

UNIQUE THREAD DESIGN

Sandvik Alpha™ features a unique thread design. The short bit thread in the tool system results in a rigid, integrated powerpack drill string with superior resistance to bending stresses, improved bit guidance and perfect energy transfer.

The sturdy thread is well guided inside the bit skirt, offering high precision in collaring – even in complex rock formations and against uneven surfaces..



ADVANTAGES

- Extended rod life (30-80%)
- Longer shank adapter life
- High penetration rate
- High precision in collaring
- Great drilling accuracy and hole straightness
- Faster and easier uncoupling of bits
- Reduced machine downtime

*Test results and calculations are to be considered as results reached under certain and controlled conditions. These test results and calculations should not be treated as specifications and Sandvik does not guarantee, warrant or represent the outcome of test results in any or all circumstances.

FACE DRILLING AND BOLTING

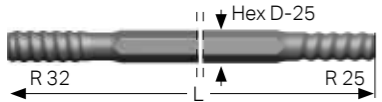
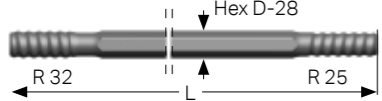
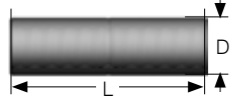

R25 (1") BIT THREAD

BITS	FLUSHING HOLE, MM		BUTTONS, MM		ANGLE	DIMENSIONS D		BIT CLASSIFICATION	PART NO.
	Front No Size	Gauge No Size	Front No Size	Gauge No Size		mm	in		
Button bit, type 52									
	1×5	1×6	2×7	5×7	45°	33	1 5/16"	●	7732-4433C-S48
	1×4	1×6	2×7	5×9	30°	35	1 3/8"	●	7732-4435-S48
	1×4	1×6	2×7	5×9	30°	35	1 3/8"	●	7732-4435-S70
	1×4	1×6	2×7	5×9	30°	35	1 3/8"	●	7732-4435-S80
	1×5	1×6	2×7	5×9	30°	37	7/16"	●	7732-4437C-S48
	1×6	1×6	2×7	5×8	40°	35	1 3/8"	●	7732-5235-R48
	1×6	1×6	2×7	5×9	35°	38	1 1/2"	●	7732-5238-R48
	1×6	1×6	2×7	5×9	35°	38	1 1/2"	●	7732-5238-S48
	1×6	1×6	2×8	5×9	35°	41	1 5/8"	●	7732-5241-S48
	Button bit, type 53								
	3×4.5	-	3×8	6×9	40°	45	1 3/4"	●	7732-5345F-R48
	3×4.5	1×4.5	3×8	6×10	30°	48	1 7/8"	●	7732-5348A-S48
Cross bit									
	1×5	2×5				35	1 3/8"	●	7732-1435-42

RODS	DIMENSIONS					PART NO.
	L mm	ft	in	D mm	in	
Drifter rod, R32 – Hex 25 – R25						
	1870	6'	1 1/2"	25	1"	7853-2418-20
	2175	7'	1 5/8"	25	1"	7853-2421-20
	2475	8'	1 1/2"	25	1"	7853-2424-20
	2630	8'	7 1/2"	25	1"	7853-2426-20
	2785	9'	1 5/8"	25	1"	7853-2427-20
	2935	9'	7 1/2"	25	1"	7853-2429-20
	3090	10'	1 5/8"	25	1"	7853-2431-20
	3340	10'	11 1/2"	25	1"	7853-2433-20
Drifter rod, R32 – Hex 28 – R25						
	2630	8'	7 1/2"	28	1 1/8"	7853-3026-20
	3090	10'	1 5/8"	28	1 1/8"	7853-3031-20
Flushing hole Ø 8.6 mm.						
Coupling sleeve, R32						
	150	-	5 29/32"	44	1 47/64"	7993-3644

FACE DRILLING AND BOLTING

R25 (1") REAMING TOOLS

	THREAD	DIMENSIONS				PART NO.	
		L mm	ft	in	D mm in		
Reaming tools for cut holes / Pilot adapter, 6° taper							
	R25	256	-	10°	26	1 1/32"	7822-2526
Reaming tools for cut holes / Reaming bit, 6° taper							
	BUTTONS, MM	ANGLE	DIMENSIONS D		PART NO.		
	Front No Size	Gauge No Size	mm	in			
	4×8	8×9	25°	64	2 1/2"	7722-4864-S48	
4×10	8×10	30°	76	3"	7722-4876-S48		
6×10	8×12	35°	89	3 1/2"	7722-4889-S48		

FACE DRILLING AND BOLTING

R28 (1 1/8") BIT THREAD

BITS	FLUSHING HOLE, MM		BUTTONS, MM		ANGLE	DIMENSIONS D		BIT CLASSIFICATION	PART NO.
	Front No Size	Gauge No Size	Front No Size	Gauge No Size		mm	in		
	1x5	1x6	2x7	5x9	30°	37	7/16"	●	7739-5237-S48
	1x6	1x6	2x7	5x9	35°	38	1 1/2"	●	7739-5238-R48
	1x6	1x6	2x7	5x9	35°	38	1 1/2"	●	7739-5238-S48
	1x6	1x6	2x7	5x9	35°	38	1 1/2"	●	7739-5238-S70
	1x6	1x6	2x7	5x9	35°	38	1 1/2"	●	7739-5238-S80
	1x6	1x6	2x8	5x9	35°	41	1 5/8"	●	7739-5241-S48
	1x6	1x6	2x8	5x10	35°	43	1 11/16"	●	7739-5243-S48

REAMING TOOLS

REAMING TOOLS	THREAD	DIMENSIONS					PART NO.
		L mm	ft	in	D mm	in	
Reaming tools for cut holes / Pilot adapter, 6° taper	R28	285	-	11 1/4"	26	1 1/32"	7822-1526



REAMING TOOLS	BUTTONS, MM	ANGLE	DIMENSIONS D		PART NO.	
			Front No Size	Gauge No Size		mm
Reaming tools for cut holes / Reaming bit, 6° taper	4x8	8x9	25°	64	2 1/2"	7722-4864-S48
	4x10	8x10	30°	76	3"	7722-4876-S48
	6x10	8x12	35°	89	3 1/2"	7722-4889-S48



RODS

RODS	DIMENSIONS					PART NO.
	L mm	ft	in	D mm	in	
Drifter rod, R32 - Hex 28 - R28	2475	8'	1 1/2"	28	1 1/8"	7853-7624-20
	2785	9'	1 5/8"	28	1 1/8"	7853-7627-20
	3090	10'	1 5/8"	28	1 1/8"	7853-7631-20
	3340	10'	11 1/2"	28	1 1/8"	7853-7633-20
	3700	12'	1 5/8"	28	1 1/8"	7853-7637-20
	4305	14'	1 1/2"	28	1 1/8"	7853-7643-20

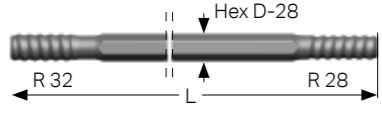

Flushing hole Ø 8.8 mm.

MF-rod, R28 - Round 32 - R28	L mm	ft	in	D mm	in	PART NO.
	3050	10'	-	32	1 1/1"	7859-5131-20
	3660	12'	-	32	1 1/1"	7859-5137-20

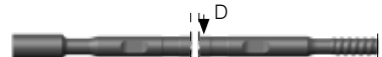

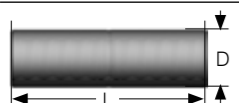

Coupling sleeve, R32	L mm	ft	in	D mm	in	PART NO.
	150		5 29/32"	44	1 47/64"	7993-3644





FACE DRILLING AND BOLTING

R32 (1 1/4") BIT THREAD

BITS	FLUSHING HOLE, MM		BUTTONS, MM		ANGLE	DIMENSIONS D		BIT CLASSIFICATION	PART NO.
	Front No Size	Gauge No Size	Front No Size	Gauge No Size		mm	in		
	3x4,5	-	3x8	6x9	10° 35°	43	1 11/16"	●	7733-6043-F49
	3x5	-	3x8	6x10	10° 35°	45	1 3/4"	●	7733-6045-F49
	3x5	-	3x9	6x10	10° 35°	48	1 7/8"	●	7733-6048-F49
	3x6	-	3x9	6x10	10° 40°	51	2"	●	7733-6051-F49

	BUTTONS, MM	ANGLE	DIMENSIONS D		PART NO.				
			Front No Size	Gauge No Size		mm	in		
	1x6	1x6	2x8	5x9	35°	41	1 5/8"	●	7733-5241-S48
	1x5	2x6	2x9	5x10	35°	43	1 11/16"	●	7733-5243A-S48
	1x5	2x6	2x9	5x10	35°	43	1 11/16"	●	7733-5243A-S70
	1x5	2x6	2x9	5x10	35°	43	1 11/16"	●	7733-5243A-S80
	1x5	2x6	2x9	5x11	30°	45	1 3/4"	●	7733-5245A-S48
	1x6	2x7,5	2x9	5x11	35°	48	1 7/8"	●	7733-5248A-S48
1x6	2x7,5	2x10	5x12	35°	51	2"	●	7733-5251A-S48	

	BUTTONS, MM	ANGLE	DIMENSIONS D		PART NO.				
			Front No Size	Gauge No Size		mm	in		
	3x4,5	1x4,5	3x8	6x9	30°	43	1 11/16"	●	7733-5343A-R48
	3x4,5	1x4,5	3x8	6x10	30°	45	1 3/4"	●	7733-5345A-R48
	3x4,5	1x4,5	3x8	6x10	25°	45	1 3/4"	●	7733-5345A-S48
	3x4,5	1x4,5	3x8	6x10	25°	45	1 3/4"	●	7733-5345A-S70
	3x4,5	1x4,5	3x8	6x10	25°	45	1 3/4"	●	7733-5345A-S80
	3x5	1x5	3x9	6x10	30°	48	1 7/8"	●	7733-5348A-R48
3x5	1x5	3x9	6x10	30°	48	1 7/8"	●	7733-5348A-S48	

	BUTTONS, MM	ANGLE	DIMENSIONS D		PART NO.				
			Front No Size	Gauge No Size		mm	in		
	3x6	1x6	3x9	6x10	40°	51	2"	●	7733-1651A-R48
	3x6	1x6	3x9	6x10	35°	51	2"	●	7733-1651A-S48
3x6	1x6	3x10	6x11	35°	57	2 1/4"	●	7733-1657A-S48	
3x7	-	3x11	6x12	30°	64	2 1/2"	●	7733-1664A-S48	

	BUTTONS, MM	ANGLE	DIMENSIONS D		PART NO.			
			Front No Size	Gauge No Size		mm	in	
2x6	2x6	2x9	6x9	40°	43	1 11/16"	●	7733-5443B-R48
2x6	2x6	2x9	6x10	35°	45	1 3/4"	●	7733-5445B-R48

	BUTTONS, MM	ANGLE	DIMENSIONS D		PART NO.			
			Front No Size	Gauge No Size		mm	in	
	3x5	1x5	3x8	6x9	40°	45	1 3/4"	○
3x6	1x6	3x9	6x9	40°	48	1 7/8"	○	7733-5548AF-F49
3x6	1x6	3x9	6x10	40°	51	2"	○	7733-5551AF-F49

	BUTTONS, MM	ANGLE	DIMENSIONS D		PART NO.			
			Front No Size	Gauge No Size		mm	in	
4x7	-	5x10	8x11	35°	76	3"	●	7733-1876-S48

	BUTTONS, MM	ANGLE	DIMENSIONS D		PART NO.			
			Front No Size	Gauge No Size		mm	in	
1x4,5	4x4,5	-	-	-	45	1 3/4"	●	7733-1345A-42

FACE DRILLING AND BOLTING

R32 (1 1/4") BIT THREAD

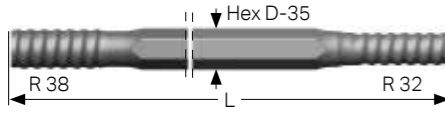
RODS	DIMENSIONS					PART NO.
	L mm	ft	in	D mm	in	
Drifter rod, R38 – Hex 35 – R32						
	3090	10'	1 5/8"	35	1 3/8"	7854-9631-20
	3700	12'	1 5/8"	35	1 3/8"	7854-9637-20
	4305	14'	1 1/2"	35	1 3/8"	7854-9643-20
	4915	16'	1 1/2"	35	1 3/8"	7854-9649-20
	5525	18'	1 1/2"	35	1 3/8"	7854-9655-20

Flushing hole Ø 9.5 mm.

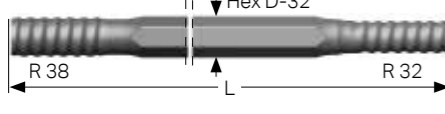
RODS	DIMENSIONS					PART NO.
	L mm	ft	in	D mm	in	
Drifter rod, R38 – Hex 32 – R32						
	2475	8'	1 1/2"	32	1 1/4"	7854-8624-20
	3090	10'	1 5/8"	32	1 1/4"	7854-8631-20
	3700	12'	1 5/8"	32	1 1/4"	7854-8637-20
	4305	14'	1 1/2"	32	1 1/4"	7854-8643-20
	4915	16'	1 1/2"	32	1 1/4"	7854-8649-20

Flushing hole Ø 9.6 mm.

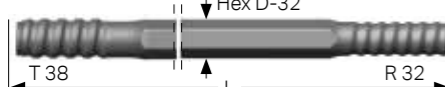
RODS	DIMENSIONS					PART NO.
	L mm	ft	in	D mm	in	
Drifter rod, T38 – Hex 32 – R32						
	3090	10'	1 5/8"	32	1 1/4"	7324-8631-20
	3700	12'	1 5/8"	32	1 1/4"	7324-8637-20
	4305	14'	1 1/2"	32	1 1/4"	7324-8643-20

Flushing hole Ø 9.6 mm.

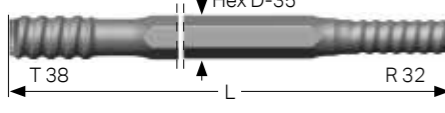
RODS	DIMENSIONS					PART NO.
	L mm	ft	in	D mm	in	
Drifter rod, T38 – Hex 35 – R32						
	2475	8'	1 1/2"	35	1 3/8"	7324-9624-20
	3090	10'	1 5/8"	35	1 3/8"	7324-9631-20
	3700	12'	1 5/8"	35	1 3/8"	7324-9637-20
	4305	14'	1 1/2"	35	1 3/8"	7324-9643-20
	4915	16'	1 1/2"	35	1 3/8"	7324-9649-20
	5525	18'	1 1/2"	35	1 3/8"	7324-9655-20
	6135	20'	1 1/2"	35	1 3/8"	7324-9661-20
	6440	21'	1 1/2"	35	1 3/8"	7324-9664-20

Flushing hole Ø 9.5 mm.

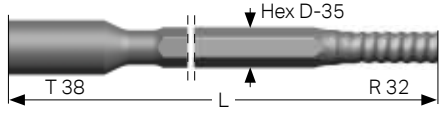

RODS	DIMENSIONS					PART NO.
	L mm	ft	in	D mm	in	
MF Drifter rod, T38 – Hex 35 – R32						
	3700	12'	1 1/2"	35	1 3/8"	7324-6537-20
	4305	14'	1 1/2"	35	1 3/8"	7324-6543-20

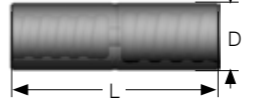

Flushing hole Ø 9.5 mm.

FACE DRILLING AND BOLTING

R32 (1 1/4") REAMING TOOLS

RODS	DIMENSIONS					PART NO.	
	L mm	ft	in	D mm	in		
Coupling sleeve							
	R38	170	-	6 3/4"	55	2 5/32"	7994-3655
	T38	191	-	7 1/2"	52	2"	7314-3652

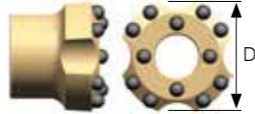





PILOT ADAPTERS 6°, 12° TAPER	THREAD	DIMENSIONS					PART NO.
		L mm	ft	in	D mm	in	
Reaming tools for cut holes / Pilot adapter, 6° taper							
	R32	285	-	11 1/4"	26	1 1/32"	7822-3526
	Reaming tools for cut holes / Pilot adapter, 12° taper						
	R32	278	-	11"	40	1 37/64"	7821-3440

REAMING BIT 6°, 12° TAPER	BUTTONS, MM		ANGLE	DIMENSIONS D		PART NO.
	Front No Size	Gauge No Size		mm	in	
Reaming tools for cut holes / Reaming bit, 6° taper						
	4×8	8×9	25°	64	2 1/2"	7722-4864-S48
	4×10	8×10	30°	76	3"	7722-4876-S48
	6×10	8×12	35°	89	3 1/2"	7722-4889-S48
Reaming tools for cut holes / Reaming bit, 12° taper						
	4×10	8×12	35°	89	3 1/2"	7721-4889-S48
	4×13	8×13	35°	102	4"	7721-4802-S48
	8×13	8×13	35°	127	5"	7721-4827-S48

REAMING BIT	FLUSHING HOLE, MM		BUTTONS, MM		ANGLE	DIMENSIONS D		PART NO.
	Front No Size	Gauge No Size	Front No Size	Gauge No Size		mm	in	
Reaming tools for cut holes / Reaming bit, R32								
	3×6	1×6	3×10	12×13	35°	102	4"	7733-5602P-S48
	3×7	1×7	3×10	16×13	35°	127	5"	7733-5627P-S48

FACE DRILLING AND BOLTING

SANDVIK ALPHA™. α330 BIT THREAD

BITS	FLUSHING HOLE, BUTTONS, MM				ANGLE		DIMENSIONS D		BIT CLASSIFICATION	PART NO.
	Front No Size	Gauge No Size	Front No Size	Gauge No Size	Front		mm	in		
					°	°				
Speedy bit, type 60										
	3×4,5	-	3×8	6×9	10°	35°	43	1 11/16"	●	7767-6043-F49
	3×5	-	3×8	6×10	10°	35°	45	1 3/4"	●	7767-6045-F49
	3×5	-	3×9	6×10	10°	35°	48	1 7/8"	●	7767-6048-F49
	3×6	-	3×9	6×10	10°	40°	51	2"	●	7767-6051-F49
Top center bit, type 51										
	2×5	1×5	2×9	7×10	10°	30°	43	1 11/16"	●	7767-5143A-S80
	2×6	1×6	2×9	7×10	10°	30°	45	1 3/4"	●	7767-5145A-S70
	2×6	1×6	2×9	7×10	10°	30°	45	1 3/4"	●	7767-5145A-S80
	3×4,5	1×4,5	3×9	8×10	10°	30°	48	1 7/8"	●	7767-5148A-S80
	3×6	1×6	3×9	8×10	10°	30°	51	2"	●	7767-5151A-S80
Button bit, type 52										
	1×5	2×6	2×9	5×10		35°	43	1 11/16"	●	7767-5243A-S48
	1×5	2×6	2×9	5×10		35°	43	1 11/16"	●	7767-5243A-S70
	1×5	2×6	2×9	5×10		35°	43	1 11/16"	●	7767-5243A-S80
	1×5	2×6	2×9	5×11		30°	45	1 3/4"	●	7767-5245A-S48
	1×6	2×7,5	2×9	5×11		35°	48	1 7/8"	●	7767-5248A-S48
Button bit, type 53/16										
	3×4,5	1×4,5	3×8	6×9		30°	43	1 11/16"	●	7767-5343A-R48
	3×4,5	1×5	3×8	6×10		30°	45	1 3/4"	●	7767-5345A-R48
	3×4,5	1×5	3×8	6×10		25°	45	1 3/4"	●	7767-5345A-S48
	3×4,5	1×4,5	3×8	6×10		25°	45	1 3/4"	●	7767-5345A-S70
	3×4,5	1×4,5	3×8	6×10		25°	45	1 3/4"	●	7767-5345A-S80
	3×5	1×5	3×9	6×10		30°	48	1 7/8"	●	7767-5348A-R48
	3×5	1×5	3×9	6×10		30°	48	1 7/8"	●	7767-5348A-S48
	3×6	1×6	3×9	6×10		40°	51	2"	●	7767-1651A-R48
	3×6	1×6	3×9	6×10		35°	51	2"	●	7767-1651A-S48
	3×7	-	3×11	6×12		30°	64	2 1/2"	●	7767-1664-S48
Button bit, type 54										
	2×6	2×6	2×9	6×9		40°	43	1 11/16"	●	7767-5443B-R48
	2×6	2×6	2×9	6×10		35°	45	1 3/4"	●	7767-5445B-R48

FACE DRILLING AND BOLTING

SANDVIK ALPHA™. α330 BIT THREAD

BITS	FLUSHING HOLE, BUTTONS, MM				ANGLE		DIMENSIONS D		BIT CLASSIFICATION	PART NO.
	Front No Size	Gauge No Size	Front No Size	Gauge No Size	Front		mm	in		
					°	°				
Button bit, type 18										
	4×7	-	5×11	8×12		35°	76	3"	●	7767-1876-S48
Button bit, Retrac										
	3×6	1×6	3×9	6×10		35°	51	2"	●	7767-4651A-S48
Cross bit										
	1×4,5	4×4,5					45	1 3/4"	●	7767-1345A-42
RODS										
DIMENSIONS										
PART NO.										
Drifter rod, T38 – Hex 35 – α330										
	2475	8'	1 1/2"	35	1 3/8"					7324-6724-20
	3090	10'	1 5/8"	35	1 3/8"					7324-6731-20
	3700	12'	1 5/8"	35	1 3/8"					7324-6737-20
	4305	14'	1 1/2"	35	1 3/8"					7324-6743-20
	4915	16'	1 1/2"	35	1 3/8"					7324-6749-20
	5525	18'	1 1/2"	35	1 3/8"					7324-6755-20
Flushing hole Ø 9.5 mm.										
Drifter rod, T38 – Round 39 – α330										
	4915	16'	1 1/2"	39	1 1/2"					7324-7049-20
	5525	18'	1 1/2"	39	1 1/2"					7324-7055-20
	6135	20'	1 1/2"	39	1 1/2"					7324-7061-20
	6440	21'	1 1/2"	39	1 1/2"					7324-7064-20
Flushing hole Ø 12.3 mm.										

FACE DRILLING AND BOLTING

SANDVIK ALPHA™. α330 BIT THREAD

COUPLING SLEEVES	DIMENSIONS					PART NO.
	L			D		
	mm	ft	in	mm	in	
Coupling sleeve, T38	191	-	7 1/2"	52	2"	7314-3652

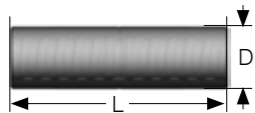

REAMING BIT	FLUSHING HOLE, MM		BUTTONS, MM		ANGLE	DIMENSIONS D		PART NO.
	Front No Size	Gauge No Size	Front No Size	Gauge No Size		mm	in	
Reaming tools for cut holes / Reaming bit, α330								
	3x6	1x6	3x10	12x13	35°	102	4"	7767-5602P-S48
	3x7	1x7	3x10	16x13	35°	127	5"	7767-5627P-S48

PILOT ADAPTER 12° TAPER	THREAD	DIMENSIONS				PART NO.	
		L			D		
		mm	ft	in	mm	in	
Reaming tools for cut holes / Pilot adapter, 12° taper							
	α330	278	-	11"	40	1 37/64"	7821-6740

REAMING BIT 12° TAPER	BUTTONS, MM		ANGLE	DIMENSIONS D		PART NO.
	Front No Size	Gauge No Size		mm	in	
Reaming tools for cut holes / Reaming bit, 12° taper						
	4x10	8x12	35°	89	3 1/2"	7721-4889-S48
	4x13	8x13	35°	102	4"	7721-4802-S48
	8x13	8x13	35°	127	5"	7721-4827-S48

FACE DRILLING AND BOLTING

SANDVIK ALPHA™. α360 BIT THREAD

BITS	FLUSHING HOLE, BUTTONS, MM				ANGLE		DIMENSIONS D		BIT CLASSIFICATION	PART NO.
	Front No Size	Gauge No Size	Front No Size	Gauge No Size	Front		mm	in		
Top center bit, type 51										
	3x5	1x5	3x9	8x10	10°	35°	48	1 7/8"	●	7581-5148A-S70
	3x5	1x5	3x9	8x10	10°	35°	48	1 7/8"	●	7581-5148A-S81

Speedy bit, type 60										
	3x5		3x9	6x10	10°	35°	48	1 7/8"	●	7581-6048-F49
	3x6		3x9	6x10	10°	40°	51	2"	●	7581-6051-F49

Button bit, type 43										
	3x5	1x5	3x9	6x10	5°	35°	48	1 7/8"	●	7581-4348A-S70
	3x5	1x5	3x9	6x10	5°	35°	48	1 7/8"	●	7581-4348A-S81
	3x5	1x5	3x8	6x10	5°	40°	49	1 15/16"	●	7581-4349A-R70
	3x6	1x6	3x9	6x11	10°	35°	51	2"	●	7581-4351A-S70

Button bit, Retrac										
	3x6	1x6	3x9	6x10		35°	51	2"	●	7581-4651A-R70
	4x7	1x7	5x9	8x10		35°	64	2 1/2"	●	7581-4864A-R70

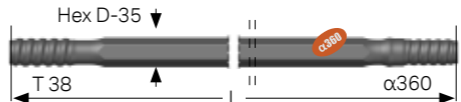
RODS	DIMENSIONS					PART NO.
	L			D		
	mm	ft	in	mm	in	
Drifter rod, T38 – Hex 35 – α360						
	3700	12'	1 1/2"	35	1 3/8"	7324-8237-20
	4305	14'	1 1/2"	35	1 3/8"	7324-8243-20
	4915	16'	1 1/2"	35	1 3/8"	7324-8249-20
	5525	18'	1 1/2"	35	1 3/8"	7324-8255-20

Flushing hole Ø 11.0 mm.

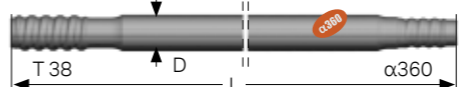
Drifter rod, T38 – Round 39 – α360						
	4915	16	1 1/2"	39	1 1/2"	7324-8149-20
	5525	18	1 1/2"	39	1 1/2"	7324-8155-20
	6135	20	1 1/2"	39	1 1/2"	7324-8161-20

Flushing hole Ø 14.5 mm.

FACE DRILLING AND BOLTING

SANDVIK ALPHA™. α360 BIT THREAD

COUPLING SLEEVES

	DIMENSIONS					PART NO.
	L	D				
	mm	ft	in	mm	in	

Coupling sleeve, T38	L	D				
	191	-	7 1/2"	52	2"	7314-3652

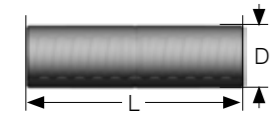

REAMING BIT

	FLUSHING HOLE, MM		BUTTONS, MM		ANGLE	DIMENSIONS D		PART NO.
	Front No Size	Gauge No Size	Front No Size	Gauge No Size		mm	in	

Reaming tools for cut holes / Reaming bit, α360

	3x6	1x6	3x13	12x13	35°	102	4"	7581-5602P-S70
	3x6	1x6	3x13	12x13	35°	102	4"	7581-5602P-S81
	3x7	1x7	3x13	16x13	35°	127	5"	7581-5627P-S70

PILOT ADAPTER 12° TAPER

	THREAD	DIMENSIONS					PART NO.
		L	D				
		mm	ft	in	mm	in	

Reaming tools for cut holes / Pilot adapter, 12° taper

	α330	278	-	11"	40	1 37/64"	7821-XXXX
---	------	-----	---	-----	----	----------	-----------

REAMING BIT 12° TAPER

	BUTTONS, MM		ANGLE	DIMENSIONS D		PART NO.
	Front No Size	Gauge No Size		mm	in	

Reaming tools for cut holes / Reaming bit, 12° taper

	4x10	8x12	35°	89	3 1/2"	7721-4889-S48
	4x13	8x13	35°	102	4"	7721-4802-S48
	8x13	8x13	35°	127	5"	7721-4827-S48

FACE DRILLING AND BOLTING

R35 (1 3/8") BIT THREAD

BITS	FLUSHING HOLE, MM		BUTTONS, MM		ANGLE		DIMENSIONS D		BIT CLASSIFICATION	PART NO.
	Front No Size	Gauge No Size	Front No Size	Gauge No Size	Front		mm	in		

Top center bit, type 51

	3x4,5	1x4,5	3x9	8x10	10°	30°	48	1 7/8"	●	7738-5148A-S80
---	-------	-------	-----	------	-----	-----	----	--------	---	----------------

Button bit, type 53/16

	3x5	1x5	3x9	6x10	30°		48	1 7/8"	●	7738-5348A-R48
	3x5	1x5	3x9	6x10	30°		48	1 7/8"	●	7738-5348A-S48

	3x6	1x6	3x9	6x10	40°		51	2"	●	7738-1651A-R48
	3x6	1x6	3x9	6x10	35°		51	2"	●	7738-1651A-S48

Cross bit

	1x5	2x7,5	-	-	-	-	48	1 7/8"	●	7738-1448-42
---	-----	-------	---	---	---	---	----	--------	---	--------------

RODS

	DIMENSIONS					PART NO.
	L	D				
	mm	ft	in	mm	in	

Drifter rod, T38 - Hex 35 - R35

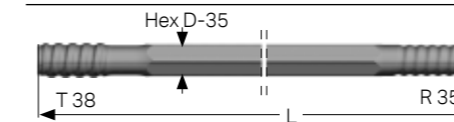
	4305	14'	1 1/2"	35	1 3/8"	7324-8543-20
	4915	16'	1 1/2"	35	1 3/8"	7324-8549-20
	5525	18'	1 1/2"	35	1 3/8"	7324-8555-20

Flushing hole Ø 9.5 mm.

Drifter rod, T38 - Round 39 - R35

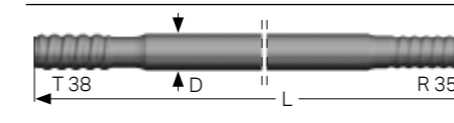
	4305	14'	1 1/2"	39	1 1/2"	7324-7243-20
	4915	16'	1 1/2"	39	1 1/2"	7324-7249-20
	5525	18'	1 1/2"	39	1 1/2"	7324-7255-20
	6135	20'	1 1/2"	39	1 1/2"	7324-7261-20

Flushing hole Ø 14.5 mm.

Drifter rod, T38 - Round 39 - R35

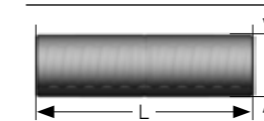
	191	-	7 1/2"	52	2"	7314-3652
---	-----	---	--------	----	----	-----------

FACE DRILLING AND BOLTING

R35 (1 3/8") BIT THREAD

REAMING BIT	FLUSHING HOLE, MM		BUTTONS, MM		ANGLE	DIMENSIONS D		PART NO.
	Front No Size	Gauge No Size	Front No Size	Gauge No Size		mm	in	

Reaming tools for cut holes / Reaming bit, R35



	3×6	1×6	3×10	12×13	35°	102	4"	7738-5602P-S48
--	-----	-----	------	-------	-----	-----	----	----------------

PILOT ADAPTER 12° TAPER	THREAD	DIMENSIONS				PART NO.
		L mm	ft	in	D mm	

Reaming tools for cut holes / Pilot adapter, 12° taper



	R35	278	-	11"	40	1 37/64"	7821-5440
--	-----	-----	---	-----	----	----------	-----------

REAMING BIT 12° TAPER	BUTTONS, MM		ANGLE	DIMENSIONS D		PART NO.
	Front No Size	Gauge No Size		mm	in	

Reaming tools for cut holes / Reaming bit, 12° taper

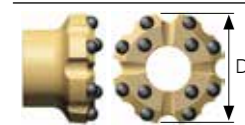

	4×10	8×12	35°	89	3 1/2"	7721-4889-S48
	4×13	8×13	35°	102	4"	7721-4802-S48
	8×13	8×13	35°	127	5"	7721-4827-S48

FACE DRILLING AND BOLTING

SANDVIK GT38

BITS	FLUSHING HOLE, MM		BUTTONS, MM		ANGLE	DIMENSIONS D		BIT CLASSIFICATION	PART NO.
	Front No Size	Gauge No Size	Front No Size	Gauge No Size		mm	in		

Button bit, Retrac



	3×7	1×7	3×10	6×11	35°	60	2 3/8"	●	7514-4660A-R48
	3×8	-	3×11	6×12	35°	64	2 1/2"	●	7514-4664-R48
	3×8	-	3×11	6×12	30°	64	2 1/2"	●	7514-4664-R70
	3×8	-	3×11	6×12	30°	64	2 1/2"	●	7514-4664-S48
	4×7	-	5×9	8×10	35°	64	2 1/2"	●	7514-4864-R48



	2×10	1×6	4×10	8×10	30°	64	2 1/2"	●	7514-7864A-S48
--	------	-----	------	------	-----	----	--------	---	----------------



	3×8	-	4×9	6×10	40°	64	2 1/2"	●	7514-7964-R48
--	-----	---	-----	------	-----	----	--------	---	---------------



RODS	DIMENSIONS						PART NO.
	Bit dia. mm	L mm	ft	in	D mm	in	

MF rod GT38 - Round 39 - GT38

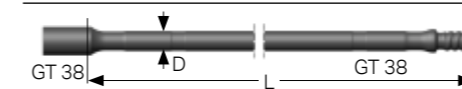

	2435	8'	-	39	1 1/2"	7324-4724M-20
	3050	10'	-	39	1 1/2"	7324-4731M-20
	4875	16'	-	39	1 1/2"	7324-4749M-20

Flushing hole Ø 14.5 mm. Female end OD 56 mm.

MF drifter lead rod, GT38 - Round 46 - T38

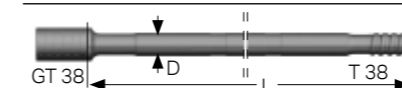

	5525	18'	1 1/2"	46	1 3/4"	7324-0755M-20
	6135	20'	1 1/2"	46	1 3/4"	7324-0761M-20

Flushing hole Ø 17 mm.

FACE DRILLING AND BOLTING

SANDVIK DRIFTER BITS

SANDVIK BITS FOR DRIFTING AND TUNNELING ARE AVAILABLE IN FIVE BASIC DESIGNS



TYPE 51

Featuring a new best-of-both-worlds carbide grade, this bit design is ideal for abrasive rock.



TYPE 52

Designed for maximum bit life in hard and abrasive rock.



TYPE 53

All-round design with a good tradeoff between speed and bit life length for hard to medium hard rock.



TYPE 54

All-round design with high penetration rate for hard to medium hard rock.



TYPE 55

Designed for maximum penetration rate in softer and less abrasive rock formations.



TYPE 60, SPEEDY BIT

The fastest bit in the industry is designed for high speed and great durability in hard to medium-hard rock.



EXTEND LIFE, REDUCE COSTS

Drill rods and tubes represent a significant part of your tool cost in bench drilling. As our industry requires increasingly deeper holes, the cost for drill rods and tubes goes up. But imagine if they were designed to last 30 percent longer, so you could drill more meters every shift and reduce your cost per meter – increasing your productivity and profit.

Sandvik +Range of friction welded rods offer better wear and fatigue resistance due to their improved heat treatment and welding process. The rods benefit from a better thread fit and coupling/uncoupling properties, plus reduced incidence of fatigue thanks to better thread surface smoothness.

WELDED, NOT FORGED

Our +Range rods are created using friction welding, rather than forged. Forged rods are forced to have the same material and heat treatment in the whole MF-rod. However, the combination of specialized heat treatments in specific parts of the + Range rods, in addition to an improved mixture of alloys in the material, allow for optimal performance.

The Sandvik +Range rods are more resilient, with improved fatigue resistance to increase service time and reduce the need to stop and replace. In addition, a smoother thread surface and new thread release reduce breakage incidence.





30% MORE LIFE

Extensive in-mine tests proved a 30 percent longer service life compared with previous standard offerings, with some achieving significantly higher increases. The patented, top-of-the-line steel alloy is designed to withstand intense heat from friction, high impact from hydraulic hammers and adhesion, which means your new rods will last much longer before they're worn out from galling and pitting. Extending the service life of your rods and tubes by an average of 30 percent means more meters drilled using fewer rods – all with far higher productivity due to reduced stops and increased drilling time.

R32 (1 1/4")	40
T35 (1 3/8")	42
T38 (1 1/2")	43
T45 (1 3/4")	45
T51 (2")	48
SANDVIK GT60	51
SANDVIK LT90	53

BENCH DRILLING

R32 (1 1/4")

BITS	FLUSHING HOLE, MM		BUTTONS, MM		ANGLE	DIMENSIONS D		BIT CLASSIFICATION	PART NO.
	Front No Size	Gauge No Size	Front No Size	Gauge No Size		mm	in		
	Button bit, regular skirt								
	3x6	1x6	3x9	6x10	40°	51	2"	●	7733-1651A-R48
	3x6	1x6	3x9	6x10	35°	51	2"	●	7733-1651A-S48
	3x6	1x6	3x10	6x11	35°	57	2 1/4"	●	7733-1657A-S48
	3x7	-	3x11	6x12	30°	64	2 1/2"	●	7733-1664-S48
	4x7	-	5x10	8x11	35°	76	3"	●	7733-1876-S48
Button bit, Retrac									
	3x6	-	3x9	6x10	35°	51	2"	●	7733-4651-R48
	3x6	-	3x9	6x10	35°	51	2"	●	7733-4651-S48
	3x8	-	3x11	6x12	30°	64	2 1/2"	●	7733-4664-S48
	4x7	-	5x9	8x10	30°	64	3 1/2"	●	7733-4864-S48

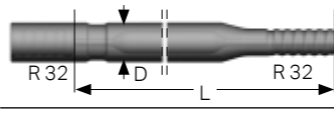
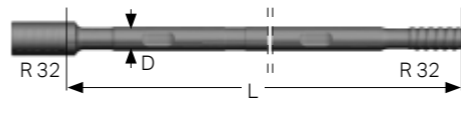
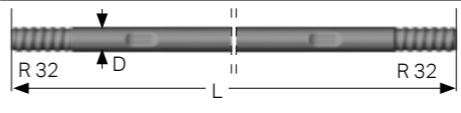
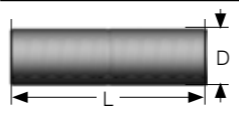

BENCH DRILLING

R32 (1 1/4")

RODS	DIMENSIONS						PART NO.
	Bit dia. mm	L mm	ft	in	D mm	in	
Guide tube							
	51-64	1830	6'	-	46	1 3/4"	7953-4618-20
	51-64	3050	10'	-	46	1 3/4"	7953-4631-20
Female end Ø 46 mm.							
MF-rod, R32 – round 32 – R32							
	2435	8'	-	-	32	1 1/4"	7853-5124-20
	3050	10'	-	-	32	1 1/4"	7853-5131-20
	3660	12'	-	-	32	1 1/4"	7853-5137-20
	4265	14'	-	-	32	1 1/4"	7853-5143-20
Flushing hole Ø 9.2 mm. Wrench flat 25.4 mm. Female end Ø 45 mm.							
Extension rod, R32 – round 32 – R32							
	2440	8'	-	-	32	1 1/4"	7853-3324-30
	3050	10'	-	-	32	1 1/4"	7853-3331-30
	3660	12'	-	-	32	1 1/4"	7853-3337-30
	4265	13'	-	-	32	3 1/4"	7853-3343-30
Flushing hole Ø 11.7 mm. Wrench flat 25.4 mm.							
Coupling sleeve R32							
	150	-	5 29/32"	44	1 47/64"	7993-3644	

BENCH DRILLING

T35 (1 3/8")



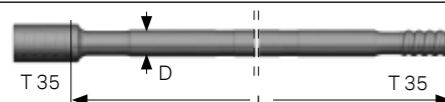





BITS	FLUSHING HOLE, MM		BUTTONS, MM		ANGLE	DIMENSIONS D		BIT CLASSIFICATION	PART NO.
	Front No Size	Gauge No Size	Front No Size	Gauge No Size		mm	in		
Button bit, regular skirt									
	3x6	1x6	3x9	6x11	30°	54	2 1/8"	●	7517-1654A-S48
Button bit, Retrac									
	3x6	-	3x9	6x10	35°	54	2 1/8"	●	7517-4654-R48
	3x8	1x8	3x11	6x12	30°	64	2 1/2"	●	7517-4654A-S81
	3x7	1x7	3x10	6x11	35°	57	2 1/4"	●	7517-4657A-R48
	3x7	1x7	3x11	6x12	35°	64	2 1/2"	●	7517-4664A-R48

RODS	DIMENSIONS					PART NO.
	L mm	ft	in	D mm	in	
MF-rod, T35 – round 39 – T35						
	3050	10'	-	39	1 1/2"	7327-4731-20
	3660	12'	-	39	1 1/2"	7327-4737-20

Female end Ø 48.2 mm. Flushing hole Ø 14.5 mm.

BENCH DRILLING

T38 (1 1/2")

BITS	FLUSHING HOLE, MM		BUTTONS, MM		ANGLE	DIMENSIONS D		BIT CLASSIFICATION	PART NO.
	Front No Size	Gauge No Size	Front No Size	Gauge No Size		mm	in		
Button bit, regular skirt									
	3x7	1x7	3x9	6x11	35°	54	2 1/8"	●	7514-1654A-R48
	3x7	1x7	3x10	6x11	35°	57	2 1/4"	●	7514-1657A-S48
	3x8	-	3x11	6x12	35°	64	2 1/2"	●	7514-1664-R48
	3x8	-	3x11	6x12	30°	64	2 1/2"	●	7514-1664-S48
	4x8	-	5x10	8x11	30°	70	2 3/4"	●	7514-1870-S48
	4x8	-	5x11	8x12	35°	76	3"	●	7514-1876-R48
	4x8	-	5x11	8x12	35°	76	3"	●	7514-1876-S48
	4x8	-	5x12	8x12	35°	89	3 1/2"	●	7514-1889-S48
	2x11	1x6	4x10	8x10	30°	64	2 1/2"	●	7514-2664A-S48
	3x8	1x8	3x10	6x11	40°	64	2 1/2"	○	7514-5564A-C60
	3x8	1x8	4x11	6x12	40°	76	3"	○	7514-5576A-C60
Button bit, Retrac									
	3x7	1x7	3x10	6x11	35°	60	2 3/8"	●	7514-4660A-R48
	3x8	-	3x11	6x12	35°	64	2 1/2"	●	7514-4664-R48
	3x8	1x8	3x11	6x12	30°	64	2 1/2"	●	7514-4664A-S81
	3x8	-	3x11	6x12	30°	64	2 1/2"	●	7514-4664-R70
	3x8	-	3x11	6x12	30°	64	2 1/2"	●	7514-4664-S48
	3x8	-	3x11	6x12	30°	64	2 1/2"	●	7514-4664-S65
	3x8	-	3x12	6x13	35°	70	3 3/4"	●	7514-4670-R70
	4x7	-	5x9	8x10	35°	64	2 1/2"	●	7514-4864-R48
	4x7	1x7	5x9	8x10	35°	64	2 1/2"	●	7514-4864A-R70
	4x8	-	5x10	8x11	30°	70	2 3/4"	●	7514-4870-S48
	4x8	-	5x11	8x12	35°	76	3"	●	7514-4876-R48
	4x8	-	5x11	8x12	35°	76	3"	●	7514-4876-S48
	4x8	-	5x11	8x12	35°	76	3"	●	7514-4876-S65
	2x10	1x6	4x10	8x10	30°	64	2 1/2"	●	7514-7864A-S48
	2x11	1x6	6x10	8x11	35°	76	3"	●	7514-7876A-S48
	3x10	-	6x10	9x11	35°	89	3 1/2"	●	7514-7889-S48
	3x8	-	4x9	6x10	40°	64	2 1/2"	●	7514-7964-R48
	4x8	-	6x10	8x11	35°	76	3"	●	7514-7976-R48
	4x7	-	6x10	8x11	30°	76	3"	●	7514-7976-S48

BENCH DRILLING

T38/T38+ (1 1/2")

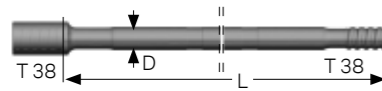
RODS	DIMENSIONS						PART NO.
	Bit dia. mm	L mm	ft	in	D mm	in	
MF-rod, T38 – round 39 – T38 	3050	10'	-		39	1 1/2"	7324-4731-85
	3660	12'	-		39	1 1/2"	7324-4737-85
	4265	14'	-		39	1 1/2"	7324-4743-85

Flushing hole Ø 14.5 mm. Female end OD 56 mm.

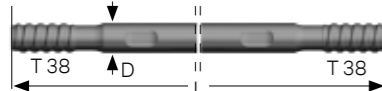
RODS	DIMENSIONS						PART NO.
	Bit dia. mm	L mm	ft	in	D mm	in	
Extension rod, T38 – round 39 – T38 	3050	10'	-		39	1 1/2"	7324-4331C-30
	3660	12'	-		39	1 1/2"	7324-4337C-30
	4265	14'	-		39	1 1/2"	7324-4343C-30

Flushing hole Ø 14.5 mm. Wrench flat 32 mm.

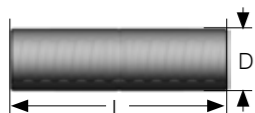
RODS	DIMENSIONS						PART NO.
Coupling sleeve T38 	191	-		7 1/2"	55	2 5/32"	7314-3355

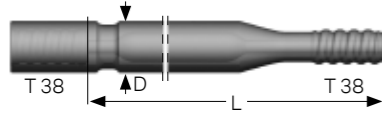

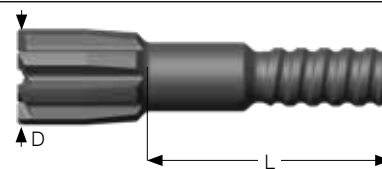

RODS	DIMENSIONS						PART NO.
Guide tube 	64-76	3660	12'	-	56	2 13/64"	7955-5637-20

Female end OD 56 mm.

GUIDE ADAPTER	DIMENSIONS			PART NO.
	T38	L mm	D mm	
Guide adapter, T38 	64	184,5	62	7334-4405-64
	76	184,5	74	7334-4405-76







BENCH DRILLING

T45 (1 3/4")

BITS	FLUSHING HOLE, MM		BUTTONS, MM		ANGLE	DIMENSIONS D		BIT CLASSIFICATION	PART NO.
	Front No	Gauge Size	Front No	Gauge No Size		mm	in		
Button bit, regular skirt 	4x8	-	5x10	8x11	30°	70	2 3/4"	●	7515-1870-S48
	4x8	-	5x11	8x12	35°	76	3"	●	7515-1876-R48
	4x8	-	5x11	8x12	35°	76	3"	●	7515-1876-S48
	4x9	-	5x12	8x13	40°	89	3 1/2"	●	7515-1889-R48
	4x9	-	5x12	8x13	35°	89	3 1/2"	●	7515-1889-S48
	3x10	-	9x11	9x13	40°	102	4"	●	7515-1902-R48
	3x10	-	9x11	9x13	35°	102	4"	●	7515-1902-S48
	2x12	1x7.5	6x10	8x11	35°	76	3"	○	7515-2676A-S48
	3x10	1x7.5	6x10	9x11	35°	89	3 1/2"	○	7515-2689A-S48
	3x10	1x9	4x11	6x12	40°	76	3"	○	7515-5576A-C60
	3x10	1x10	2x11, 3x12	6x13	40°	89	3 1/2"	○	7515-5589A-C60

BENCH DRILLING

T45 (1 3/4")

BITS	FLUSHING HOLE, MM		BUTTONS, MM		ANGLE	DIMENSIONS D		BIT CLASSIFICATION	PART NO.	
	Front No Size	Gauge No Size	Front No Size	Gauge No Size		mm	in			
Button bit, Retrac 	4x7	-	5x9	8x10	35°	66	2 19/32"	●	7515-4866-R48	
	4x8	-	5x10	8x11	35°	70	2 3/4"	●	7515-4870-R48	
	4x8	-	5x11	8x12	35°	76	3"	●	7515-4876-R48	
	4x8	-	5x11	8x12	35°	76	3"	●	7515-4876-R70	
	4x8	-	5x11	8x12	35°	76	3"	●	7515-4876-S48	
	4x8	-	5x11	8x12	35°	76	3"	●	7515-4876-S65	
	4x8	-	5x11	8x12	35°	76	3"	●	7515-4876-S70	
	4x8	-	5x11	8x12	35°	76	3"	●	7515-4876-S81	
	4x8	-	5x11	8x12	40°	83	3 1/4"	●	7515-4883-R70	
	4x9	-	5x12	8x13	40°	89	3 1/2"	●	7515-4889-R70	
	4x9	-	5x12	8x13	35°	89	3 1/2"	●	7515-4889-S48	
	4x9	-	5x12	8x13	35°	89	3 1/2"	●	7515-4889-S70	
		3x10	-	9x11	9x13	40°	102	4"	●	7515-4902-R48
		3x10	-	9x11	9x13	35°	102	4"	●	7515-4902-S48
		3x9	1x9	1x11, 3x11	6x12	40°	76	3"	○	7515-7576A-C60
		3x10	1x10	2x11, 3x12	6x13	40°	89	3 1/2"	○	7515-7589A-C60
		2x11	1x6	6x10	8x11	35°	76	3"	●	7515-7876A-S48
		3x10	1x8	6x10	9x11	35°	89	3 1/2"	●	7515-7889A-S48
	4x8	-	6x10	8x11	35°	76	3"	●	7515-7976-R48	
	4x7	-	6x10	8x11	30°	76	3"	●	7515-7976-S48	
	4x8	-	6x11	8x12	40°	89	3 1/2"	●	7515-7989-R48	
	4x8	-	6x11	8x12	35°	89	3 1/2"	●	7515-7989-S48	
	4x8	-	6x10	8x11	35°	76	3"	●	7515-8276-R48	

BENCH DRILLING

T45/T45+ (1 3/4")

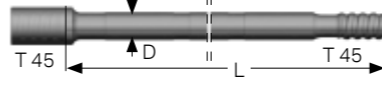
RODS	DIMENSIONS						PART NO.
	Bit dia. mm	L mm	ft	in	D mm	in	
MF-rod, T45 – round 46 – T45 	3050	10'	-	46	1 1/2"	7325-7731-85	
	3660	12'	-	46	1 1/2"	7325-7737-85	
	4265	14'	-	46	1 1/2"	7325-7743-85	
	4975	16'	-	46	1 1/2"	7325-7749-85	
	6095	20'	-	46	1 1/2"	7325-7761-85	

Flushing hole Ø 17 mm. Female end Ø 63 mm.

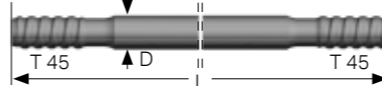
RODS	DIMENSIONS						PART NO.
	Bit dia. mm	L mm	ft	in	D mm	in	
Extension rod, T45 – round 46 – T45 	3050	10'	-	46	1 3/4"	7325-7331C-30	
	3660	12'	-	46	1 3/4"	7325-7337C-30	
	4265	14'	-	46	1 3/4"	7325-7343C-30	

Flushing hole Ø 17 mm.

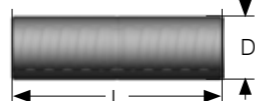
RODS	DIMENSIONS						PART NO.
	Bit dia. mm	L mm	ft	in	D mm	in	
Coupling sleeve T45 	210	-	8 1/8"	63	2 31/64"	7315-3663	

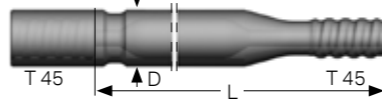

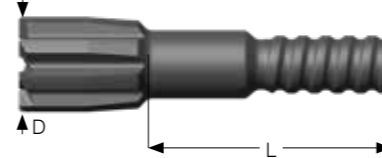

RODS	DIMENSIONS						PART NO.
	Bit dia. mm	L mm	ft	in	D mm	in	
Guide tube 	76-89	3660	12'	-	63	2 1/2"	7956-6337-70
	89-102	3660	12'	-	76	3"	7956-7637-70

Female end Ø 63 mm / 76 mm.

GUIDE ADAPTER	DIMENSIONS			PART NO.
	T45	L mm	D mm	
Guide adapter, T45 	76	199,5	74	7335-5405-76
	83	199,5	81	7335-5405-83
	89	199,5	86	7335-5405-89









BENCH DRILLING

T51 (2")

BITS	FLUSHING HOLE, MM		BUTTONS, MM		ANGLE	DIMENSIONS D		BIT CLASSIFICATION	PART NO.
	Front No Size	Gauge No Size	Front No Size	Gauge No Size		mm	in		
	4x10	-	5x12	8x13	40°	89	3 1/2"	●	7516-1889-R48
	4x10	-	5x12	8x13	35°	89	3 1/2"	●	7516-1889-S48
	3x13	-	9x11	9x13	40°	102	4"	●	7516-1902-R48
	3x13	-	9x11	9x13	35°	102	4"	●	7516-1902-S48
	3x13	-	10x12	9x14	35°	115	4 1/2"	●	7516-1915-S48
	3x14	-	10x13	9x14	35°	127	5"	●	7516-1927-S48
	3x12	1x8	6x10	9x11	35°	89	3 1/2"	●	7516-2689A-S48
	3x12	1x12	2x11, 3x12	6x13	40°	89	3 1/2"	○	7516-5589A-C60
	4x11	1x11	3x11, 4x12	8x13	40°	102	4"	○	7516-5502A-C60
	4x11	1x11	3x12, 4x12	8x13	40°	115	4 1/2"	○	7516-5515A-C60

BENCH DRILLING

T51 (2")

BITS	FLUSHING HOLE, MM		BUTTONS, MM		ANGLE	DIMENSIONS D		BIT CLASSIFICATION	PART NO.
	Front No Size	Gauge No Size	Front No Size	Gauge No Size		mm	in		
	4x9	-	5x12	8x13	35°	83	3 1/4"	●	7516-4883-R70
	4x9	-	5x12	8x13	40°	83	3 1/4"	●	7516-4883-S48
	4x10	-	5x12	8x13	35°	89	3 1/2"	●	7516-4889-S48
	4x10	-	5x12	8x13	35°	89	3 1/2"	●	7516-4889-S70
	4x10	-	5x12	8x13	35°	89	3 1/2"	●	7516-4889-R70
	4x10	-	5x12	8x13	35°	89	3 1/2"	●	7516-4889-S81
	3x13	-	9x11	9x13	40°	102	4"	●	7516-4902-R48
	3x13	-	9x11	9x13	35°	102	4"	●	7516-4902-S48
	3x13	-	9x11	9x13	35°	102	4"	●	7516-4902-S70
	3x13	-	10x12	9x14	40°	115	4 1/2"	●	7516-4915-R48
	3x13	-	10x12	9x14	35°	115	4 1/2"	●	7516-4915-S48
	3x13	-	10x12	9x14	35°	115	4 1/2"	●	7516-4915-S70
	3x14	-	10x13	9x14	35°	127	5"	●	7516-4927-S48
	3x12	1x12	2x11, 3x12	6x13	40°	89	3 1/2"	○	7516-7589A-C60
	3x11	1x11	3x11, 4x12	8x13	40°	102	4"	○	7516-7502A-C60
	3x12	1x8	6x10	9x11	35°	89	3 1/2"	●	7516-7889A-S48
	4x10	-	6x11	8x12	40°	89	3 1/2"	●	7516-7989-R48
	4x10	-	6x11	8x12	35°	89	3 1/2"	●	7516-7989-S48
	4x11	-	7x12	8x13	35°	102	4"	●	7516-7902-S48
	4x11	-	3x11, 4x12	8x13	40°	102	4"	●	7516-7902-R48
	4x10	-	3x12, 4x13	8x14	35°	115	4 1/2"	●	7516-7915-S48
	3x12	1x8	6x10	9x11	35°	89	3 1/2"	●	7516-7889A-S48
	5x9	-	7x11	10x12	35°	89	3 1/2"	●	7516-7089-S70
	5x10	-	8x12	10x13	35°	102	4"	●	7516-7002-S70

BENCH DRILLING

T51/T51+ (2")

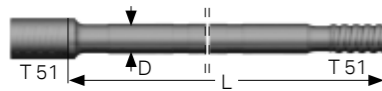
RODS	DIMENSIONS						PART NO.
	Bit dia. mm	L mm	ft	in	D mm	in	
MF-rod, T51 – round 52 – T51 	3660	12'	–	52	2"	7326-5537-70	
	3660	12'	–	52	2"	7326-5537-85	
	4265	14'	–	52	2"	7326-5543-85	
	4875	16'	–	52	2"	7326-5549-85	
	5485	17'	–	52	2"	7326-5555-85	
	6095	20'	–	52	2"	7326-5561-85	

Flushing hole Ø 21.5 mm. Female end Ø 71 mm.

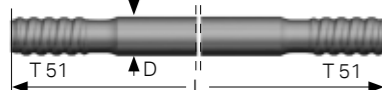
Extension rod, T51 – round 52 – T51 	DIMENSIONS						PART NO.
	Bit dia. mm	L mm	ft	in	D mm	in	
	3660	12'	–	52	2"	7326-5337C-30	
	4265	14'	–	52	2"	7326-5343C-30	
6095	20'	–	52	2"	7326-5361C-30		

Flushing hole Ø 21.5 mm.

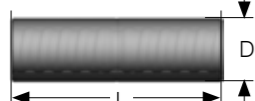
Coupling sleeve T51 	DIMENSIONS						PART NO.
	Bit dia. mm	L mm	ft	in	D mm	in	
	225	–	8 7/8"	71	2 51/64"	7316-3671	
	225	–	8 7/8"	76	3"	7316-3676	

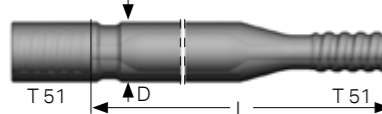





Guide tube 	DIMENSIONS						PART NO.
	Bit dia. mm	L mm	ft	in	D mm	in	
	89–102	3660	12'	–	76	3"	7957-7637-70
	102–127	3660	12'	–	87	3 1/2"	7957-8737-70

Female end Ø 76 / 87 mm.

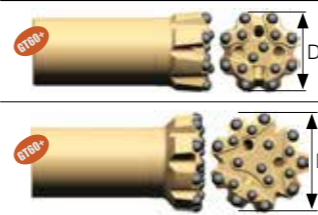
GUIDE ADAPTER 	DIMENSIONS			PART NO.
	T51	L mm	D mm	
Guide adapter, T51	83	222,5	80	7336-6405-83
	89	222,5	86	7336-6405-89
	102	222,5	98	7336-6405-102
	115	222,5	111	7336-6405-115

BENCH DRILLING

SANDVIK GT60+

BITS	FLUSHING HOLE, MM		BUTTONS, MM		ANGLE	DIMENSIONS D		BIT CLASSIFICATION	PART NO.	
	Front No Size	Gauge No Size	Front No Size	Gauge No Size		mm	in			
Button bit, regular skirt 	4×11	–	6×12	8×14	35°	92	3 5/8"	●	7620-1892-S48	
	4×12	–	6×12	8×14	35°	96	3 3/4"	●	7620-1896-S48	
	3×13	–	9×11	9×13	35°	102	4"	●	7620-1902-S48	
	3×14	–	10×12	9×14	40°	115	4 1/2"	●	7620-1915-R48	
	3×14	–	10×12	9×14	35°	115	4 1/2"	●	7620-1915-S48	
	3×14	–	10×13	9×16	35°	127	5"	●	7620-1927-S48	
	3×14	–	10×14	9×16	35°	140	5 1/2"	●	7620-1940-S48	
	3×14	–	10×14	9×16	35°	140	5 1/2"	●	7620-1940-S70	
	3×15	–	12×14	9×16	35°	152	6"	●	7620-1952-S48	
	Button bit, Retrac 	3×13	–	9×11	9×13	35°	102	4"	●	7620-4902-S48
		3×13	–	9×11	9×13	35°	102	4"	●	7620-4902-S70
		3×14	–	10×12	9×14	40°	115	4 1/2"	●	7620-4915-R48
3×14		–	10×12	9×14	35°	115	4 1/2"	●	7620-4915-S48	
3×14		–	10×12	9×14	35°	115	4 1/2"	●	7620-4915-S70	
3×14		–	10×13	9×14	40°	127	5"	●	7620-4927-R48	
3×14		–	10×13	9×16	35°	127	5"	●	7620-4927-S48	
3×14		–	10×13	9×16	35°	127	5"	●	7620-4927-S55	
3×14		–	10×13	9×16	35°	127	5"	●	7620-4927-S70	
3×14		–	10×13	9×16	35°	127	5"	●	7620-4927-S81	
3×14		–	10×14	9×16	35°	140	5 1/2"	●	7620-4940-S48	
3×14		–	10×14	9×16	35°	140	5 1/2"	●	7620-4940-S70	
3×15	–	12×14	9×16	35°	152	6"	●	7620-4952-S48		
	4×11	–	3×11, 4×12	8×13	35°	102	4"	●	7620-7902-S48	
	4×11	–	3×12, 4×13	8×14	35°	115	4 1/2"	●	7620-7915-S48	
	4×11	–	3×13, 4×14	8×14	35°	127	5"	●	7620-7927-S48	
	4×12	–	4×14, 4×16	8×16	35°	140	5 1/2"	●	7620-7940-S48	
	4×12	–	5×14, 4×16	8×16	35°	152	6"	●	7620-7952-S48	
	2×14	–	9×12	9×12	40°	92	3 5/8"	○	7620-8792-R48	
	2×14	–	9×12	9×12	35°	92	3 5/8"	●	7620-8792-S48	
	2×14	–	10×12	9×13	40°	96	3 3/4"	○	7620-8796-R48	
	2×14	–	10×12	9×13	35°	96	3 3/4"	●	7620-8796-S48	
	2×14	–	10×12	9×13	40°	102	4"	○	7620-8702-R48	
	2×15	–	6×13	8×16	35°	102	4"	●	7620-8102-S70	
	3×13	–	6×13	9×16	35°	115	4 1/2"	●	7620-8115-S55	
	3×13	–	6×13	9×16	35°	115	4 1/2"	●	7620-8115-S70	
	3×13	–	6×13	9×16	35°	115	4 1/2"	●	7620-8115-S81	
	5×10	–	8×12	10×13	35°	102	4"	●	7620-7002-S70	

BENCH DRILLING

SANDVIK GT60+

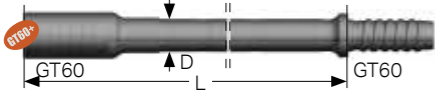
RODS	DIMENSIONS					PART NO.
	L mm	ft	in	D mm in		
MF-rod, GT60 – round 60 – GT60. For bits from 96 mm.						
	3660	12'	–	60	2 3/8"	7610-1137-85
	4265	14'	–	60	2 3/8"	7610-1143-85
	4875	16'	–	60	2 3/8"	7610-1149-85
	5485	18'	–	60	2 3/8"	7610-1155-85
	6095	20'	–	60	2 3/8"	7610-1161-85

Female end Ø 85 mm. Flushing hole Ø 22.5 mm.

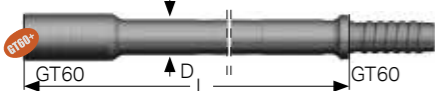
	4265	14'	–	64	2 1/2"	7610-1243-85
---	------	-----	---	----	--------	--------------

Female end Ø 85 mm. Flushing hole Ø 25 mm.

MF-rod, GT60 – round 60 – GT60. For 92–115 mm bits.						
	3660	12'	–	60	2 3/8"	7610-1437-85
	4265	14'	–	60	2 3/8"	7610-1443-85

Female end Ø 82 mm. Flushing hole Ø 22.5 mm.

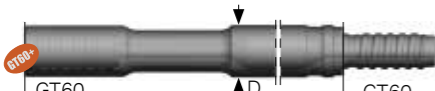
Pilot tube – GT60	DIMENSIONS					PART NO.
	L mm	ft	in	D mm in		
	1600	5'	3'	87	3"	7640-8716-80
	4265	14'	–	87	3 1/2"	7640-8743-80
	5335	17'	6'	76	3"	7640-7653-80

Female end Ø 85 mm (82 mm on 76 mm tubes).

Drill tube	DIMENSIONS					PART NO.
	L mm	ft	in	D mm in		
	4265	14'	–	87	3 1/2"	7660-8743-80
	6095	20'	–	87	3 1/2"	7660-8761-80

Always use with tube shank adapter 7600-6030-01 (HL1500, 1560).

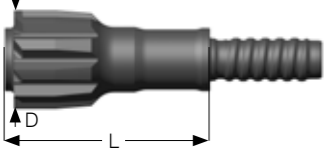
GUIDE ADAPTER	DIMENSIONS			PART NO.
	GT60	L mm	D mm	
Guide adapter, GT60				
	96	244,5	93	7630-6005-96
	102	244,5	99	7630-6005-102
	115	244,5	111	7630-6005-115
	127	264,5	123	7630-6005-127
	140	284,5	136	7630-6005-140
	157	284,5	147	7630-6005-152

BENCH DRILLING

SANDVIK LT90

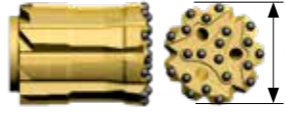
BITS	FLUSHING HOLE, MM		BUTTONS, MM		ANGLE	DIMENSIONS D		BIT CLASSIFICATION	PART NO.
	Front No	Gauge No	Front No	Gauge No		mm	in		
LT90 Assortment, TH, XL									
	3×15	–	10×14	9×16	35°	140	5 1/2"	●	7532-4940-S48
	3×20	–	12×14	9×16	35°	152	6"	●	7532-4952-S48
	3×20	–	12×16	9×16	35°	165	6 1/2"	●	7532-4965-S70
	3×20	–	12×16	9×18	35°	172	6 3/4"	●	7532-4972-R70
	3×20	–	12×16	9×18	35°	178	7"	●	7532-4978-R70

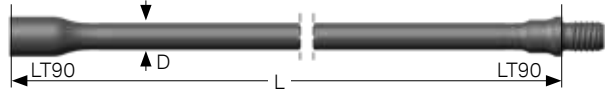
RODS	DIMENSIONS					PART NO.
	L mm	ft	tube	D mm in		
MF-rod, LT90 – round 80						
	4265	14'	–	80	–	7382-1543-85

Female end Ø 120 mm. Flushing hole Ø 50 mm.

SHANKS	APPLICATION	DIMENSIONS		PART NO.
		L mm	D mm	
RD1840C				
	BE	850	80	7340-6040-15
	BE/RP	850	80	7340-6040P-15*

*RockPulse, Release in Sept 2021

PRODUCTION POWER ACCURACY & RELIABILITY



Production drilling is at the very heart of your mine. It is therefore vital that you choose products that deliver the accuracy and quality you demand. Developments in underground mining are leading towards large-scale production with fewer sublevels, longer holes and more selective mining, and our offering will help prepare you for your future needs.

This trend naturally makes drilling accuracy more important than ever. Many factors can influence the straightness of the drill hole: rock and ore properties, the drilling method, the power and set-up of the drill rig, and the correct choice of drilling tools. In this context, a Sandvik MF rod string is a tolerant and forgiving tool system. In addition, it also delivers impressive hole straightness.

With our unique in-house manufacturing facilities for producing, machining and tailoring steel, we are able to modify the metallurgical properties of all crucial Sandvik MF rod components. This is why all of our rod strings are given specific material characteristics in order to maximize wear, fatigue and corrosion resistance. Ultimately, this





boosts your drilling performance by making operations simple and ensuring productivity at all times. In long-hole production drilling, the main advantage of our tube drilling system is the high rate of penetration: the straightness and quality of the drill-holes and the low total production cost.

Our hole diameters range between 76 and 115 mm. A correctly assembled tube string in a stable rig permits the accurate drilling of holes up to 60 meters. This benefits your bottom line. Hole deviation adversely affects profitability in the form of poor fragmentation, low ore recovery and ore dilution. Using our tools has been proven to reduce deviation by up to 40 percent.

R32 (1 1/4")	58
T35 (1 3/8")	60
T38 (1 1/2")	61
T45 (1 3/4")	63
T51 (2")	65
ST58 (2 1/4") TUBE DRILLING TOOLS	67
ST68 (2 3/4") TUBE DRILLING TOOLS	68





LONG-HOLE DRILLING UNDERGROUND

R32 (1 1/4")

BITS	FLUSHING HOLE, MM		BUTTONS, MM		ANGLE	DIMENSIONS D		BIT CLASSIFICATION	PART NO.
	Front No Size	Gauge No Size	Front No Size	Gauge No Size		mm	in		
Button bit, regular skirt									
	3×6	1×6	3×9	6×10	40°	51	2"	●	7733-1651A-R48
	3×6	1×6	3×9	6×10	35°	51	2"	●	7733-1651A-S48
	3×6	1×6	3×10	6×11	35°	57	2 1/4"	●	7733-1657A-S48
	3×7	–	3×11	6×12	30°	64	2 1/2"	●	7733-1664-S48
	4×7	–	5×11	8×12	35°	76	3"	●	7733-1876-S48
	Button bit, Retrac								
	3×6	–	3×9	6×10	35°	51	2"	●	7733-4651-R48
	3×6	–	3×9	6×10	35°	51	2"	●	7733-4651-S48
	3×8	–	3×11	6×12	30°	64	2 1/2"	●	7733-4664-S48
	4×7	–	5×9	8×10	30°	64	3 1/2"	●	7733-4864-S48

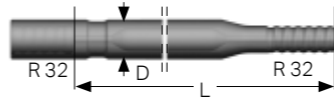
LONG-HOLE DRILLING UNDERGROUND

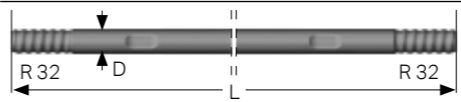

R32 (1 1/4")

RODS	DIMENSIONS						PART NO.
	Bit dia. mm	L mm	ft	in	D mm	in	
Guide tube	51–64	1830	6'	–	46	1 3/4"	7953-4618-20
 <p>Female end Ø 46 mm.</p>							
MF-rod, R32 – round 32 – R32		915	3'	–	32	1 1/4"	7853-5109-20
							
		1220	4'	–	32	1 1/4"	7853-5112-20
		1525	5'	–	32	1 1/4"	7853-5115-20
		1830	6'	–	32	1 1/4"	7853-5118-20
Flushing hole Ø 11.7 mm. Wrench flat 25.4 mm. Female end Ø 45 mm.							
Extension rod, R32 – round 32 – R32		1220	4'	–	32	1 1/4"	7853-3312-20
							
		1525	5'	–	32	1 1/4"	7853-3315-20
		1830	6'	–	32	1 1/4"	7853-3318-20
Flushing hole Ø 11.7 mm. Wrench flat 25.4 mm.							
Coupling sleeve R32		150	–	5 29/32"	44	1 47/64"	7993-3644
							

REAMING BIT	FLUSHING HOLE, MM		BUTTONS, MM		ANGLE	DIMENSIONS D		PART NO.
	Front No Size	Gauge No Size	Front No Size	Gauge No Size		mm	in	
Reaming bit, R32								
	3×6	1×6	3×10	12×13	35°	102	4"	7733-5602P-S48
	3×7	1×7	3×10	16×13	35°	127	5"	7733-5627P-S48

LONG-HOLE DRILLING UNDERGROUND









T35 (1 3/8")

BITS	FLUSHING HOLE, MM		BUTTONS, MM		ANGLE	DIMENSIONS D		BIT CLASSIFICATION	PART NO.
	Front No Size	Gauge No Size	Front No Size	Gauge No Size		mm	in		
Button bit, regular skirt									
	3x6	1x6	3x9	6x11	30°	54	2 1/8"	●	7517-1654A-S48
Button bit, Retrac									
	3x6	-	3x9	6x10	35°	54	2 1/8"	●	7517-4654-R48
	3x8	1x8	3x11	6x12	30°	64	2 1/2"	●	7517-4654A-S81
	3x7	1x7	3x10	6x11	35°	57	2 1/4"	●	7517-4657A-R48
	3x7	1x7	3x11	6x12	35°	64	2 1/2"	●	7517-4664A-R48

RODS	DIMENSIONS					PART NO.
	L mm	ft	in	D mm	in	
MF-rod, T35 - Round 39 - T35						
	1525	5'	-	39	1 1/2"	7327-4715-20
	1830	6'	-	39	1 1/2"	7327-4718-20

LONG-HOLE DRILLING UNDERGROUND

T38 (1 1/2")

BITS	FLUSHING HOLE, MM		BUTTONS, MM		ANGLE	DIMENSIONS D		BIT CLASSIFICATION	PART NO.
	Front No Size	Gauge No Size	Front No Size	Gauge No Size		mm	in		
Button bit, regular skirt									
	3x7	1x7	3x9	6x11	35°	54	2 1/8"	●	7514-1654A-R48
	3x7	1x7	3x10	6x11	35°	57	2 1/4"	●	7514-1657A-S48
	3x8	-	3x11	6x12	35°	64	2 1/2"	●	7514-1664-R48
	3x8	-	3x11	6x12	30°	64	2 1/2"	●	7514-1664-S48
	4x8	-	5x10	8x11	30°	70	2 3/4"	●	7514-1870-S48
	4x8	-	5x11	8x12	35°	76	3"	●	7514-1876-R48
	4x8	-	5x11	8x12	35°	76	3"	●	7514-1876-S48
	4x8	-	5x12	8x12	35°	89	3 1/2"	●	7514-1889-S48
	2x11	1x6	4x10	8x10	30°	64	2 1/2"	●	7514-2664A-S48
	3x8	1x8	3x10	6x11	40°	64	2 1/2"	○	7514-5564A-C60
	3x8	1x8	4x11	6x12	40°	76	3"	○	7514-5576A-C60
Button bit, Retrac									
	3x7	1x7	3x10	6x11	35°	60	2 3/8"	●	7514-4660A-R48
	3x8	-	3x11	6x12	35°	64	2 1/2"	●	7514-4664-R48
	3x8	1x8	3x11	6x12	30°	64	2 1/2"	●	7514-4664A-S81
	3x8	-	3x11	6x12	30°	64	2 1/2"	●	7514-4664-R70
	3x8	-	3x11	6x12	30°	64	2 1/2"	●	7514-4664-S48
	3x8	-	3x11	6x12	30°	64	2 1/2"	●	7514-4664-S65
	3x8	-	3x12	6x13	35°	70	3 3/4"	●	7514-4670-R70
	4x7	-	5x9	8x10	35°	64	2 1/2"	●	7514-4864-R48
	4x8	-	5x10	8x11	30°	70	2 3/4"	●	7514-4870-S48
	4x8	-	5x11	8x12	35°	76	3"	●	7514-4876-R48
	4x8	-	5x11	8x12	35°	76	3"	●	7514-4876-S48
	4x8	-	5x11	8x12	35°	76	3"	●	7514-4876-S65
	2x10	1x6	4x10	8x10	30°	64	2 1/2"	●	7514-7864A-S48
	2x11	1x6	6x10	8x11	35°	76	3"	●	7514-7876A-S48
	3x10	-	6x10	9x11	35°	89	3 1/2"	●	7514-7889-S48
	3x8	-	4x9	6x10	40°	64	2 1/2"	●	7514-7964-R48
	4x8	-	6x10	8x11	35°	76	3"	●	7514-7976-R48
	4x7	-	6x10	8x11	30°	76	3"	●	7514-7976-S48

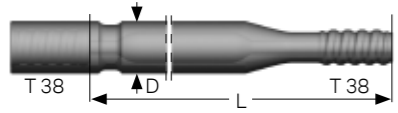
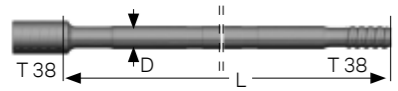

LONG-HOLE DRILLING UNDERGROUND

T38 (1 1/2")

RODS	DIMENSIONS						PART NO.
	Bit dia. mm	L mm	ft	in	D mm	in	
Guide tube 	64-76	1220	4'	-	56	2 13/64"	7955-5612-20
	64-76	1830	6'	-	56	2 13/64"	7955-5618-20
Female end OD 56 mm.							
MF-rod, T38 – round 39 – T38 	915	3'	-	39	1 1/2"	7324-4709C-20	
	1220	4'	-	39	1 1/2"	7324-4712C-20	
	1525	5'	-	39	1 1/2"	7324-4715C-20	
	1830	6'	-	39	1 1/2"	7324-4718C-20	









Flushing hole Ø 14.5 mm. Female end OD 56 mm.

PILOT ADAPTER	THREAD	DIMENSIONS				PART NO.	
		L mm	ft	in	D mm		in
Pilot adapter for reaming of 64 mm (2") pilot holes							
	T38	-	-	-	47	1 7/8"	7823-2647

REAMER	BUTTONS, MM		ANGLE	DIMENSIONS D		FLUSH- ING HOLE	PILOT DIAM. mm	BIT CLASSI- FICATION	PART NO.
	Front No Size	Gauge No Size		mm	in				
Reaming bit 	4x12	8x12	35°	102	4"	-	-	-	7723-4802-S48
	4x12	8x12	35°	127	5"	-	-	-	7723-4827-S48
	4x14	8x14	35°	127	5"	4x9	57	-	7514-5627-S48
	7x14	8x14	35°	152	6"	4x9	57	-	7514-5652-S48

LONG-HOLE DRILLING UNDERGROUND

T45 (1 3/4")

BITS	FLUSHING HOLE, MM		BUTTONS, MM		ANGLE	DIMENSIONS D		BIT CLASSI- FICATION	PART NO.	
	Front No Size	Gauge No Size	Front No Size	Gauge No Size		mm	in			
Button bit, regular skirt										
	4x8	-	5x10	8x11	30°	70	2 3/4"	●	7515-1870-S48	
	4x8	-	5x11	8x12	35°	76	3"	●	7515-1876-R48	
	4x8	-	5x11	8x12	35°	76	3"	●	7515-1876-S48	
	4x9	-	5x12	8x13	40°	89	3 1/2"	●	7515-1889-R48	
	4x9	-	5x12	8x13	35°	89	3 1/2"	●	7515-1889-S48	
	3x10	-	9x11	9x13	40°	102	4"	●	7515-1902-R48	
	3x10	-	9x11	9x13	35°	102	4"	●	7515-1902-S48	
	Button bit, Retrac									
	4x7	-	5x9	8x10	35°	66	2 19/32"	●	7515-4866-R48	
	4x8	-	5x10	8x11	35°	70	2 3/4"	●	7515-4870-R48	
	4x8	-	5x11	8x12	35°	76	3"	●	7515-4876-R48	
	4x8	-	5x11	8x12	35°	76	3"	●	7515-4876-R70	
	4x8	-	5x11	8x12	35°	76	3"	●	7515-4876-S48	
	4x8	-	5x11	8x12	35°	76	3"	●	7515-4876-S65	
	4x8	-	5x11	8x12	35°	76	3"	●	7515-4876-S70	
	4x8	-	5x11	8x12	35°	76	3"	●	7515-4876-S81	
	4x8	-	5x11	8x12	40°	83	3 1/4"	●	7515-4883-R48	
	4x9	-	5x12	8x13	40°	89	3 1/2"	●	7515-4889-R48	
	4x9	-	5x12	8x13	40°	89	3 1/2"	●	7515-4889-R70	
	4x9	-	5x12	8x13	35°	89	3 1/2"	●	7515-4889-S48	
	3x10	-	9x11	9x13	40°	102	4"	●	7515-4902-R48	
	3x10	-	9x11	9x13	35°	102	4"	●	7515-4902-S48	
	Button bit, Retrac									
		3x9	1x9	1x11, 3x11	6x12	40°	76	3"	○	7515-7576A-C60
		3x10	1x10	2x11, 3x12	6x13	40°	89	3 1/2"	○	7515-7589A-C60
		2x11	1x6	6x10	8x11	35°	76	3"	●	7515-7876A-S48
		3x10	1x8	6x10	9x11	35°	89	3 1/2"	●	7515-7889A-S48
		4x8	-	6x10	8x11	35°	76	3"	●	7515-7976-R48
4x7		-	6x10	8x11	30°	76	3"	●	7515-7976-S48	
4x8		-	6x11	8x12	40°	89	3 1/2"	●	7515-7989-R48	
4x8		-	6x11	8x12	35°	89	3 1/2"	●	7515-7989-S48	
	4x8	-	6x10	8x11	35°	76	3"	●	7515-8276-R48	

LONG-HOLE DRILLING UNDERGROUND

T45 (1 3/4")

BITS	BUTTONS, MM		ANGLE	DIMENSIONS D		FLUSHING HOLE	PILOT DIAM.	BIT CLASSIFICATION	PART NO.
	Front No Size	Gauge No Size		mm	in				
Reaming bit	4×14	8×14	35°	127	5"	4×9	64	-	7515-5627-S48
	8×14	8×14	35°	152	6"	4×9	64	-	7515-5652-S48

RODS	DIMENSIONS						PART NO.
	Bit dia. mm	L mm	ft	in	D mm	in	

Guide tube							
	76	1830	6'	-	63	2 31/64"	7956-6318-21
	84	1830	6'	-	76	3"	7956-7618-20

Female end Ø 63 mm / 76 mm..

MF-rod, T45 – round 46 – T45

	1220	4'	-	46	1 3/4"	7325-7712C-20
	1525	5'	-	46	1 3/4"	7325-7715C-20
	1830	6'	-	46	1 3/4"	7325-7718C-20

Flushing hole Ø 17 mm. Female end Ø 63 mm.

BITS - FOR TUBE DRILLING	FLUSHING HOLE, MM		BUTTONS, MM		ANGLE	DIMENSIONS D		BIT CLASSIFICATION	PART NO.
	Front No Size	Gauge No Size	Front No Size	Gauge No Size		mm	in		
XDC, button bit	4×7.5	-	6×10	8×11	35°	76	3"	●	7525-8476-R65

Button bit retrac									
	4×8	-	5×11	8×12	35°	76	3"	●	7525-4876-S48
	4×9	-	5×12	8×13	35°	89	3 1/2"	●	7525-4889-S65
	4×8	-	5×11	8×13	35°	76	3"	●	7525-9076-S70

TUBES	DIMENSIONS						PART NO.
	L mm	ft	in	D mm	in		

Drill tube, T45 – Round 65 – T45							
	1525	5'	-	65	2 1/2"	7985-6315-26	
	1830	6'	-	65	2 1/2"	7985-6318-26	

Flushing hole Ø 18 mm.

LONG-HOLE DRILLING UNDERGROUND

T51 (2")

BITS	FLUSHING HOLE, MM		BUTTONS, MM		ANGLE	DIMENSIONS D		BIT CLASSIFICATION	PART NO.
	Front No Size	Gauge No Size	Front No Size	Gauge No Size		mm	in		
Button bit, regular skirt	4×10	-	5×12	8×13	40°	89	3 1/2"	●	7516-1889-R48
	4×10	-	5×12	8×13	35°	89	3 1/2"	●	7516-1889-S48
	3×13	-	9×11	9×13	40°	102	4"	●	7516-1902-R48
	3×13	-	9×11	9×13	35°	102	4"	●	7516-1902-S48
	3×13	-	10×12	9×14	35°	115	4 1/2"	●	7516-1915-S48
	3×14	-	10×13	9×14	35°	127	5"	●	7516-1927-S48
	3×12	1×8	6×10	9×11	35°	89	3 1/2"	●	7516-2689A-S48
	3×12	1×12	2×11, 3×12	6×13	40°	89	3 1/2"	○	7516-5589A-C60
	4×11	1×11	3×11, 4×12	8×13	40°	102	4"	○	7516-5502A-C60
	4×11	1×11	3×12, 4×12	8×13	40°	115	4 1/2"	○	7516-5515A-C60

LONG-HOLE DRILLING UNDERGROUND

T51 (2")

BITS	FLUSHING HOLE, MM		BUTTONS, MM		ANGLE	DIMENSIONS D		BIT CLASSIFICATION	PART NO.
	Front No Size	Gauge No Size	Front No Size	Gauge No Size		mm	in		
	Button bit, Retrac								
	4x9	-	5x12	8x13	35°	83	3 1/4"	●	7516-4883-R70
	4x9	-	5x12	8x13	40°	83	3 1/4"	●	7516-4883-S48
	4x10	-	5x12	8x13	35°	89	3 1/2"	●	7516-4889-S48
	4x10	-	5x12	8x13	35°	89	3 1/2"	●	7516-4889-S65
	4x10	-	5x12	8x13	35°	89	3 1/2"	●	7516-4889-S70
	4x10	-	5x12	8x13	35°	89	3 1/2"	●	7516-4889-R70
	4x10	-	5x12	8x13	35°	89	3 1/2"	●	7516-4889-S81
		3x13	-	9x11	9x13	40°	102	4"	●
3x13		-	9x11	9x13	35°	102	4"	●	7516-4902-S48
3x13		-	9x11	9x13	35°	102	4"	●	7516-4902-S65
3x13		-	10x12	9x14	40°	115	4 1/2"	●	7516-4915-R48
3x13		-	10x12	9x14	35°	115	4 1/2"	●	7516-4915-S48
	3x14	-	10x13	9x14	35°	127	5"	●	7516-4927-S48
	3x12	1x12	2x11, 3x12	6x13	40°	89	3 1/2"	○	7516-7589A-C60
	3x11	1x11	3x11, 4x12	8x13	40°	102	4"	○	7516-7502A-C60
	3x12	1x8	6x10	9x11	35°	89	3 1/2"	●	7516-7889A-S48
	4x10	-	6x11	8x12	40°	89	3 1/2"	●	7516-7989-R48
	4x10	-	6x11	8x12	35°	89	3 1/2"	●	7516-7989-S48
	4x11	-	7x12	8x13	35°	102	4"	●	7516-7902-S48
	4x11	-	3x11, 4x12	8x13	40°	102	4"	●	7516-7902-R48
	4x10	-	3x12, 4x13	8x14	35°	115	4 1/2"	●	7516-7915-S48
	3x12	1x8	6x10	9x11	35°	89	3 1/2"	●	7516-7889A-S48
	5x9	-	7x11	10x12	35°	89	3 1/2"	●	7516-7089-S70
	5x10	-	8x12	10x13	35°	102	4"	●	7516-7002-S70
Reaming bit									
	4x9	-	8x14	8x14	35°	152	6"	-	7516-5652-S48

Pilot diameter: 64 mm.







LONG-HOLE DRILLING UNDERGROUND

T51 (2")

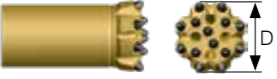
RODS	DIMENSIONS						PART NO.
	Bit dia. mm	L mm	ft	in	D mm	in	
Guide tube	89-102	1830	6'	-	76	3"	7957-7618-20
<p>Female end Ø 76 mm.</p>							
MF-rod, T51 – round 52 – T51		1220	4'	-	52	2"	7326-5512C-20
		1525	5'	-	52	2"	7326-5515C-20
		1830	6'	-	52	2"	7326-5518C-20
<p>Flushing hole Ø 21 mm. Female end Ø 71 mm.</p>							

LONG-HOLE DRILLING UNDERGROUND

ST58 (2 1/4") TUBE DRILLING TOOLS

BITS	FLUSHING HOLE, MM		BUTTONS, MM		ANGLE	DIMENSIONS D		BIT CLASSIFICATION	PART NO.
	Front No Size	Gauge No Size	Front No Size	Gauge No Size		mm	in		
Autobit, regular skirt	4×10	–	6×12	8×13	40°	89	3 1/2"	●	7528-6289-F70
									
Autobit, Retrac	4×10	–	6×12	8×13	40°	89	3 1/2"	●	7528-6389-F70
									
XDC, button bit	4×10	–	6×12	8×12	35°	89	3 1/2"	●	7528-8489-R65
									
	4×10	–	6×12	8×12	35°	89	3 1/2"	●	7528-8489-R70
XDC, button bit, guide Retrac	4×10	–	4×12	10×12	35°	89	3 1/2"	●	7528-7389-R65
									
	4×10	–	6×12	10×12	35°	89	3 1/2"	●	7528-7389-R70
	4×10	–	8×12	10×12	35°	102	4"	●	7528-7302-R70
	4×10	–	8×14	10×14	35°	115	4 1/2"	●	7528-7315-R70
Button bit, Heavy Duty	2×14	–	6×12	8×14	35°	89	3 1/2"	●	7528-6989-S65
									
Retrac bit, Heavy Duty	3×12	–	8×11	9×13	35°	89	3 1/2"	●	7528-8589-S70
									
	3×12	–	8×11	9×13	35°	89	3 1/2"	●	7528-8589-S81
Reaming bit	4×9	–	4×14	8×14	35°	127	5"	–	7528-5627-S81
									
	4×9	2×9	8×14	8×14	35°	152	6"	–	7528-5652-S81
	3×16	–	9×16	9×16	35°	204	8"	–	7528-5604-S81



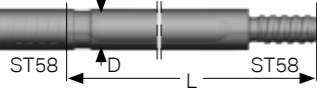





Pilot diameter 76 mm 7528-5652-S81.
Pilot diameter 137 mm 7528-5604-S81.

TUBES	DIMENSIONS					PART NO.
	L mm	ft	in	D mm	in	
Drill tube, ST58 – Round 76 – ST58						
	1525	5'	–	76	3"	7378-7615-26
	1830	6'	–	76	3"	7378-7618-26

Flushing hole Ø 26 mm.

LONG-HOLE DRILLING UNDERGROUND

ST68 (2 3/4") TUBE DRILLING TOOLS

BITS	FLUSHING HOLE, MM		BUTTONS, MM		ANGLE	DIMENSIONS D		BIT CLASSIFICATION	PART NO.
	Front No Size	Gauge No Size	Front No Size	Gauge No Size		mm	in		
Autobit, regular skirt	3×13	–	9×12	9×14	40°	102	4"	●	7529-6202-F70
									
Autobit, Retrac	3×13	–	9×12	9×14	40°	102	4"	●	7529-6302-F70
									
XDC, button bit	4×10	–	8×12	10×12	35°	102	4"	●	7529-8402-R65
									
	4×10	–	8×12	10×12	35°	102	4"	●	7529-8402-R70
	4×10	–	8×14	10×14	35°	115	4 1/2"	●	7529-8415-R70
XDC, button bit, guide Retrac	4×10	–	8×12	10×12	35°	102	4"	●	7529-7302-R65
									
	4×10	–	8×12	10×12	35°	102	4"	●	7529-7302-R70
	4×10	–	8×14	10×14	35°	115	4 1/2"	●	7529-7315-R65
	4×10	–	8×12	10×12	35°	102	4"	●	7529-7302-R48
Button bit, Heavy Duty	2×15	–	5×14	8×16	35°	102	4"	●	7529-6902-S65
									
Collaring bit	3×18	–	8×16	9×16	35°	152	6"	●	7529-6652-S48
									
Retrac bit, Heavy Duty	2×15	–	5×14	8×16	35°	102	4"	●	7529-8902-S65
									
	2×15	–	5×14	8×16	35°	102	4"	●	7529-8902-S81
Reaming bit	4×9	–	4×16	8×16	35°	152	6"	–	7529-5652-S81
									
	3×16	–	9×16	9×16	35°	204	8"	–	7529-5604-S81
	3×16	–	9×16	9×18	35°	254	10"	–	7529-5654-S65

Pilot diameter 95 mm 7529-5652-S81.
Pilot diameter 137 mm 7529-5604-S81.
Pilot diameter 188 mm 7529-5654-S65.

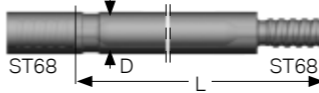
TUBES	DIMENSIONS					PART NO.
	L mm	ft	in	D mm	in	
Drill tube, ST68 – Round 87 – ST68						
	1525	5'	–	87	3 1/2"	7379-8715-26
	1830	6'	–	87	3 1/2"	7379-8718-26

Flushing hole Ø 30 mm.

RELIABLE PERFORMANCE THAT CUTS COSTS

While every component in the drill string is crucial, the shank adapter must be engineered to transmit impact energy from the rock-drill piston – along with rotation torque – into the drill string with no losses. It must withstand and transmit up to 6,300 blows per minute from the piston continually, and do so with great endurance and dependability.





With this in mind, we manufacture premium quality shank adapters for most brands of rock drills. We have yet more specially developed products that are not featured in this catalog. Please visit our website or contact us directly to find out more, and to order the shank adapter that will keep you drilling.

HEXAGONAL SHANK ADAPTERS	70
SANDVIK	71
HYDRASTAR / TOYO	77
EPIROC	78
BOART	81
FURUKAWA	82
GARDNER-DENVER, INGERSOLL-RAND & KLEMM	83
MONTABERT	84

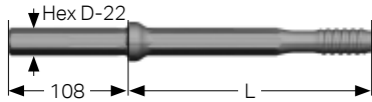

SHANK RODS

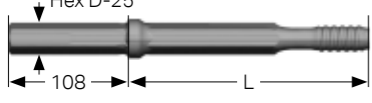

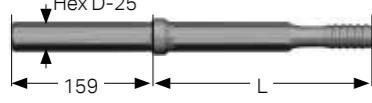
HEXAGONAL SHANK RODS

	FLUSHING TUBE (MM)	THREAD	LENGTH (MM)	PART NO.
For hexagonal bushing 22 × 108 mm				
	4.5-5.0	R22	255	7801-6103-11
	4.5-5.0	R23	255	7807-6103-11 
	4.5-5.0	R25	255	7802-6103-11
For hexagonal bushing 25 × 108 mm				
	4.5-5.0	R23	255	7807-7103-30 
For hexagonal bushing 25 × 159 mm				
	8	R25	255	7802-7103-21

 No packing. Not suitable for hydraulic machines with water flushing.

SHANK ADAPTERS

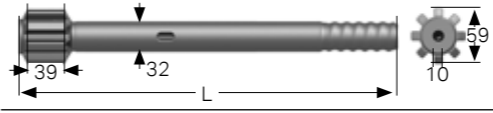
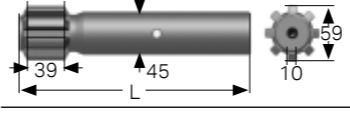
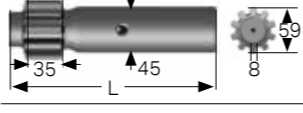
SANDVIK

	APPLICATION	THREAD	LENGTH (MM)	PART NO.
HLX 1, RD106				
	TU, BO	R23	235	7807-7570-01
	TU, BO	R25	255	7802-7567-01
	TU, BO	R28	255	7809-7567-01
HL300				
	BE	R32	400	7803-7549-01
HL300S				
	BO, TU	R32F	245	7803-7547-01
RD308, RD314, RD414				
	UG	R32F	205	7803-7663-01
	UG	R32	410	7803-7672-01
	UG	T38	410	7304-7672-01

 S = For underground drilling, T = Drill with stabilizer

SHANK ADAPTERS

SANDVIK

	APPLICATION	THREAD	LENGTH (MM)	PART NO.
	TU	R32	500	7803-7585-01
	TU	T38	500	7304-7585-01
	TU	R38	500	7804-7585-01
	BE	R32	575	7803-7586-01
	BE	T35	575	7307-7586-01
	BE	T38	575	7304-7586-01
	BE	T45	575	7305-7586-01
	TU	T38	575	7304-7664-01
	TU	T45	575	7305-7664-01
	TU	T35	745	7307-7673-01
	TU	T38	745	7304-7673-01
	TU	T38	525	7304-7669-01
	TU	T45	525	7305-7669-01
	TU	T38	600	7304-7666-01
	TU	T38	745	7304-7685-01

! PE = For Power Extractor rock drill, S = For underground drilling, T = Drill with stabilizer

SHANK ADAPTERS

SANDVIK

	APPLICATION	THREAD	LENGTH (MM)	PART NO.
	BE	R32	550	7803-7535-02
	BE	T38	550	7304-7535-02
	PD, TU	R32	460	7803-7531-01
	TU	R38	460	7804-7531-01
	PD, TU	T38	460	7304-7531-01
	TU	R38	500	7804-7536-01
	PD, TU	T38	500	7304-7536-01
	TU	T35	460	7307-7566-01
	TU	R38	500	7804-7554-01
	TU	T38	500	7304-7554-01
	PD, TU	T35	550	7307-7557-01
	BE	R32	550	7803-7557-01
	BE	T38	550	7304-7557-01
BE	T45	550	7305-7557-01	
	Tubes, BE	T45	600	7305-7532-01
	BE	T38	600	7304-7576-01
	BE	T45	600	7305-7576-01
	BE	R32	600	7803-7577-02
	BE, PD	T38	600	7304-7577-02
	BE	T45	600	7305-7577-02
	BE	T51	600	7306-7577-03

! PE = For Power Extractor rock drill, S = For underground drilling, T = Drill with stabilizer

SHANK ADAPTERS

SANDVIK

	APPLICATION	THREAD	LENGTH (MM)	PART NO.
RD900, RD900 PE, RD900 PE/RP				
	BE	T38	600	7304-7711-15
	BE	T45	600	7305-7711-15
	BE/RP	T45	600	7305-7711P-15
	BE	T51	600	7306-7711-15
	BE/RP	T51	600	7306-7711P-15
RD900, RD900 PE, RD900 PE/RP				
	BE	T45	820	7305-7721-15
	BE/RP	T45	820	7305-7721P-15
	BE	T51	820	7306-7721-15
	BE/RP	T51	820	7306-7721P-15
RD900, RD900 RP				
	BE	T51	670	7306-7715-15
	BE/RP	T51	670	7306-7715P-15
RD900 PE				
	BE/PE	T51	670	7306-7716-15
	BE/PE	T51	670	7306-7716P-15
	BE/PE	ST58	670	7358-7716-15
	BE/PE	GT60	670	7600-7716-15
	BE/PE	GT60	670	7600-7716P-15
RD900 PE TUBE				
	BE	T45	670	7305-7717-15
RD900 TUBE				
	BE	T45	670	7305-7714-15
RD900				
	PD	ST58	670	7328-7718-15
RD900, RD900 RP				
	BE	GT60	820	7600-7728-15
	BE	GT60	820	7600-7728P-15

! PE = For Power Extractor rock drill, S = For underground drilling, T = Drill with stabilizer, RP = RockPulse

SHANK ADAPTERS



SANDVIK

	APPLICATION	THREAD	LENGTH (MM)	PART NO.
HL1000, HL1000S, HL1010, HL1010S				
	PD	T45	590	7305-6008-01
	BE	T51	670	7306-6010-02
HL1000, HL1010				
	BE	T51	670	7306-6014-02
	BE	GT60	670	7600-6014-02
HL1000 PE, HL1010 PE, HL1060T, HL1060T PE, HL1560T, HL1560T PE				
	BE	T51	760	7306-6025-02
	BE	ST58	760	7358-6025-02
	BE	GT60	760	7600-6025-02
	BE	GT60	760	7600-6025-85
HL1500T				
	BE	GT60	760	7600-6022-03
HF1560, HF1560 PE				
	BE	GT60	760	7600-6025-05
	BE	GT60	760	7600-6025-85

! PE = For Power Extractor rock drill, S = For underground drilling, T = Drill with stabilizer, RP = RockPulse

SHANK ADAPTERS

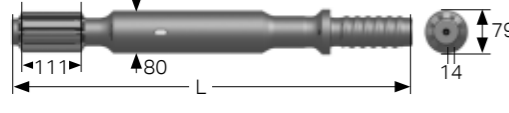
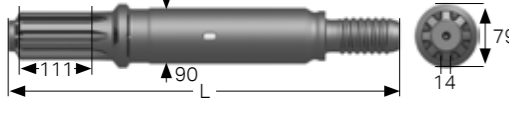

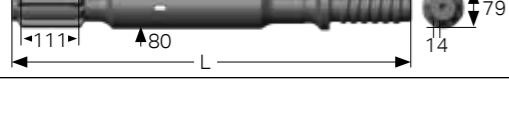
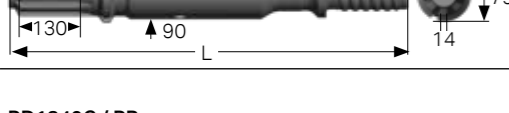
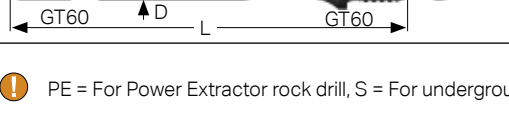
SANDVIK

	APPLICATION	THREAD	LENGTH (MM)	PART NO.
HL1560ST 	PD	ST58	635	7328-6020-01
	PD	ST68	635	7329-6020-05
HL1060T, HL1500T, HL1560T, HF1560T 	BE	GT60	760	7600-6030-05
	BR	GT60	760	7600-6030-85
HL1500ST PE, HL1560ST PE 	PD	ST58	635	7328-6035-01
	PD	ST68	635	7329-6035-05
HL1010 PE, HL1010S PE, HL1060T PE, HL1500T PE, HL1560T PE 	BE	GT60	760	7600-6032-05
	BE	GT60	760	7600-6032-85
RD1635CF 	BE	GT60	760	7600-6025-12
	BE	GT60	760	7600-6025-85
RD1635CF 	BE	GT60	760	7600-6030-15
RD1635CF PE 	BE	GT60	760	7600-6032-15
	BE	GT60	760	7600-6032-85
RD1840C / RP 	BE	LT90	850	7340-6040-15
	BE/RP	LT90	850	7340-6040P-15

PE = For Power Extractor rock drill, S = For underground drilling, T = Drill with stabilizer

SHANK ADAPTERS

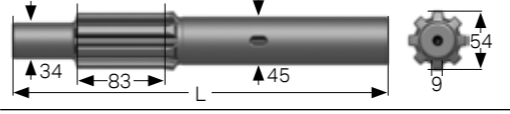
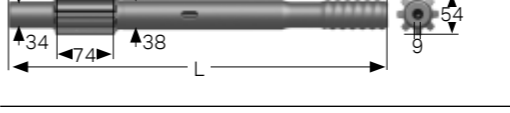
HYDRASTAR / TOYO

	APPLICATION	THREAD	LENGTH (MM)	PART NO.
Hydrastar 200 	TU, BO	R32F	351	7803-4703-01
Hydrastar 200, Hydrastar 300, Hydrastar 350, Hydrastar X2 	TU	R32	485	7803-3590-03
	TU	R38	485	7804-3590-03
	TU	T38	485	7304-3590-03
Toyo PR 220 	BE	R32	330	7803-7500-61
	BE	T38	446	7304-7500-60

PE = For Power Extractor rock drill, S = For underground drilling, T = Drill with stabilizer

SHANK ADAPTERS

EPIROC

	APPLICATION	THREAD	LENGTH (MM)	PART NO.
COP MD20				
	TU	R38	470	7804-3685-01
	TU	T38	470	7304-3685-01
	TU	T38	560	7304-3687-01
Epiroc COP 1036, COP 1038, COP 1238				
	TU	R32	485	7803-3590-03
	TU	R38	485	7804-3590-03
	TU	T38	485	7304-3590-03
Epiroc COP RR11, COP 1132				
	BO	R32	410	7803-3581-02
	PD	R32	500	7803-3583-02
Epiroc COP RR14, COP 1140, COP 1435				
	BO, TU	R32	410	7803-3704-01
Epiroc COP RR14, COP SC14, COP 1435				
	BO	R32	500	7803-3705-01
Epiroc COP 1440, COP 1550, COP 1638HD+, COP 1838HD+, COP 2238HD+, RD 14U, RD 18U				
	TU	R38	435	7804-3652-01
	TU	T38	435	7304-3652-01
	TU	R32	435	7803-3652-01
	BE, PD	R32	525	7803-3656-02
	BE, PD	T38	525	7304-3656-01
Epiroc COP 1550, COP 1638+, COP 1838+, COP 1838HE+, COP 2238+				
	BE, PD	T38	525	7304-3655-01
	BE, PD	T45	525	7305-3655-01
Epiroc COP 1550 EX, COP 1838 EX				
	BE	T45	730	7305-3826-02

SHANK ADAPTERS

EPIROC

	APPLICATION	THREAD	LENGTH (MM)	PART NO.
Epiroc COP 1838MUX+, COP 1838 HUX+				
	BE, PD	T38	730	7304-3663-01
	BE, PD	T45	730	7305-3663-01
Epiroc COP SC16, COP 1240, COP 1640				
	BE, PD	T35	565	7307-3690-01
Epiroc COP SC16, COP SC19, COP 1240, COP 1640				
	BE, PD	T38	565	7304-3690-02
Epiroc COP SC16, COP SC19, COP SC25-HF, COP 1240, COP 1640, COP 1840, COP 2540				
	BE, PD	T45	565	7305-3690-02
Epiroc COP SC19, COP SC25-HF, COP 1840, COP 2540				
	PE, PD	T51	565	7306-3690-03

HANDHELD AND SMALL-HOLE DRILLING

FACE DRILLING AND BOLTING

BENCH DRILLING

LONG-HOLE DRILLING UNDERGROUND

SHANK ADAPTERS

AUXILIARY TOOLS

INFORMATION AND BIT CLASSIFICATION GUIDE

GRINDING EQUIPMENT

SHANK ADAPTERS

EPIROC

	APPLICATION	THREAD	LENGTH (MM)	PART NO.
Epiroc COP 2160, COP 2560 	BE	T51	770	7306-3689-01
Epiroc COP 2160EX/2560EX 	BE	T51	770	7306-3699-01
	BE	GT60	770	7600-3699-01
Epiroc COPSC25-HE, COP 2160, COP 2160+, COP 2560, COP 2560+ 	BE	T45	770	7305-3701-01
	BE	T51	770	7306-3701-01
Epiroc COP SC25X-HE, COP 2160EX, COP 2560EX+ 	BE	T45	770	7305-3700-01
	BE	T51	770	7306-3700-01
Epiroc COP 3060MEX/60 	BE	GT60	840	7600-3682-01
Epiroc COP 3038 	S	T45	435	7305-3667-01
COP 4050ME 	BE	GT60	700	7600-3712-01
Epiroc COP 4050MUX 	BE,PD	ST58	835	7328-3720-01
	BE,PD	ST68	835	7329-3720-01

! S = For underground drilling

SHANK ADAPTERS

BOART

	APPLICATION	THREAD	LENGTH (MM)	PART NO.
Boart HD 125, HD 150, HD 160 	TU	T38	495	7304-4993-01

HANDHELD AND SMALL-HOLE DRILLING

FACE DRILLING AND BOLTING

BENCH DRILLING

LONG-HOLE DRILLING UNDERGROUND

SHANK ADAPTERS

AUXILIARY TOOLS

INFORMATION AND BIT CLASSIFICATION GUIDE

GRINDING EQUIPMENT

SHANK ADAPTERS

FURUKAWA

	APPLICATION	FLUSHING HOLE (MM)	THREAD	LENGTH (MM)	PART NO.
Furukawa M 120 and PD 200					
	BE	14	T38	380	7304-7543-60
	BE	14	T38	446	7304-7500-60
Furukawa HD 709					
	BE	-	T38	620	7304-7426-01
Furukawa HD 712					
	BE	-	T45	788	7305-7417-01
Furukawa HD 715 RP					
	BE	-	T35	885	7306-7424-01

SHANK ADAPTERS

GARDNER-DENVER, INGERSOLL-RAND AND KLEMM

	APPLICATION	FLUSHING HOLE (MM)	THREAD	LENGTH (MM)	PART NO.
Gardner-Denver PR 123					
	TU, BE	14	T38	446	7304-7500-60
	TU, BE	14	T38	380	7304-7543-60
Ingersoll-Rand URD 475, URD 550, VL120, EVL 130, VL140 and F16					
	BE	14	T38	380	7304-7543-60
	BE	14	T38	446	7304-7500-60
Ingersoll-Rand YH 65, YH 80					
	BE	19	T38	495	7304-7525-19
	BE	19	T45	500	7305-7525-19
Ingersoll-Rand YH 80 A					
	BE	19	T45	495	7305-7559-19
Ingersoll-Rand YH 65 RP, YH 70 RP, YH 75 RP, YH 80 RP					
	BE	19	T45	700	7305-7546-19
Klemm 4053					
	BE	-	R55	500	7805-6015 ¹⁾
	BE	-	R55	500	7805-7015 ²⁾

- 1) LH-Rotation
- 2) RH-Rotation

SHANK ADAPTERS

MONTABERT

	APPLICATION	THREAD	LENGTH (MM)	PART NO.
Montabert HC 40				
	BE	R32	447	7803-4725-01
	BE	R38	447	7804-4725-01
	BE	T38	447	7304-4725-01
Montabert HC 40 (female)				
	TU, BO	R32	270	7803-4726-01
Montabert HC 80, HC 90, HC 105				
	TU	T38	440	7304-4720-01
Montabert HC 80R, HC 105R, HC 107R, HC 108R, HC 109R				
	BE	T38	670	7304-7544-01
	BE	T45	670	7305-7544-01
Montabert HC 120R, HC 150R, HC 155R, HC 158R				
	BE	T51	670	7306-7528-02
Montabert HC 200A				
	BE	GT60	840	7600-7530-02

! S = For underground drilling

HANDHELD AND
SMALL-HOLE DRILLING

FACE DRILLING
AND BOLTING

BENCH DRILLING

LONG-HOLE DRILLING
UNDERGROUND

SHANK ADAPTERS

AUXILIARY TOOLS

INFORMATION AND BIT
CLASSIFICATION GUIDE

GRINDING EQUIPMENT

TOP-GRADE TOOLS TO KEEP YOU MOVING

Auxiliary tools are an important part of the drilling application. This is why we provide top-grade tools in order to keep your process moving, and to avoid unnecessary and costly downtime. Our accessories for top hammer drilling tools are simple, practical additions. Their purpose is to enable the tool system to

be tailored to meet your different demands, in different applications and working environments. Furthermore, our auxiliary tools optimize your system, providing higher productivity and reliability with lower operating costs and minimal environmental impact.

BIT ADAPTERS	88
REDUCTION COUPLINGS	88
WRENCHES / KNOCK-OFF TOOLS	88
FISHING TOOLS	89
THREAD GREASE	89



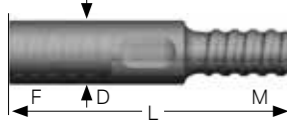

AUXILIARY TOOLS

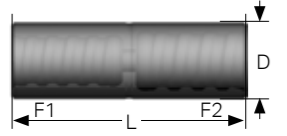
BIT ADAPTERS	WRENCH FLAT	THREADS		DIMENSIONS				PART NO.
		F (Female)	M (Male)	L (mm)	L (in)	D (mm)	D (in)	
	38	R25	R32	173	6 13/16"	45	1 3/4"	7832-3301
	38	R28	R32	230	9 1/16"	40	1 37/64"	7839-3301
	38	R32	R38	225	8 55/64"	45	1 49/64"	7833-4301
	38	R32	T38	225	8 55/64"	45	1 49/64"	7833-4401
	38	T35	T38	250	9 27/32"	48	1 7/8"	7337-4401
	44.5	R38	T38	245	9 21/32"	55	2 5/32"	7834-4401
	44.5	T38	R32	270	10 41/64"	57	2 1/4"	7334-3301
	44.5	T38	T45	285	11 7/32"	57	2 1/4"	7334-5401
	38	T45	T38	265	10 7/16"	63	2 31/64"	7335-4401
	44.5	T45	T51	285	11 7/32"	63	2 31/64"	7335-6401
	44.5	T51	T45	285	11 7/32"	71	2 51/64"	7336-5401

REDUCTION COUPLINGS	THREADS		DIMENSIONS				PART NO.
	F1	F2	L (mm)	L (in)	D (mm)	D (in)	
	R32	R28	165	6 1/2"	44	1 47/64"	7993-0444
	R32	R25	160	6 1/4"	43	1 11/16"	7993-2443
	R38	R32	170	6 3/4"	55	2 5/32"	7994-3455
	T38	R32	195	7 11/16"	55	2 5/32"	7314-3555
	T38	R38	183	7 9/32"	55	2 5/32"	7314-4455
	T38	T45	180		58	2 9/32"	7314-6258
	T38	T45	180	8 43/64"	61	2 13/32"	7314-6261
	T51	T45	218	8 19/32"	71	2 51/64"	7316-6271

SPLIT SET DRIVERS	CONNECTION	SPLIT-SET SIZE	D (mm)	D (mm)	L (mm)	PART NO.
	H22x108	33 mm	21	27,5	338	7979-2221
	H22x108	39 mm	26	32,5	318	7979-2226
	T38	39 mm	26	32,5	174	7979-2626
	T38	46 mm	30	36,5	174	7979-2630
	R38	39 mm	26	32,5	174	7979-4526
	R38	46 mm	30	36,5	174	7979-4530

KNOCK-OFF TOOLS	PART NO.
For Hex 22 and Hex 25 	Pilot rods, type 7922-XXXX-XX 795-1469
For tapered bits 	Hex 22 795-1467

AUXILIARY TOOLS

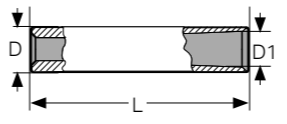
FISHING TOOLS	DIMENSIONS			Thread	PART NO.	
	D	D1	L			
	R32 round/Hex. rods/coupling sleeves	49	47.2	300	R32	795-1604A
	R38 round rods/coupling sleeves	60	-	353	R38	795-1605
	T35 round rods/coupling sleeves	52	50	284	T35	795-1613
	T38 round rods/coupling sleeves/MF-rods	61	58.2	353	T38	795-1607A
	T45 round rods/coupling sleeves	71	67	275	T45	795-1614
	T51 round rods/coupling sleeves/MF-rods	82	78.2	440	T51	795-1609A
	GT60 rods	92	87.5	450	GT60	795-2601
	ST68	102	91	385	ST68	795-1696

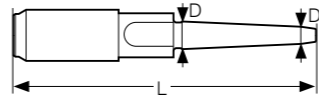
Fishing pike					
	R32 rods ¹⁾	19.4	4	280	R32 795-1606
	T38 rods ²⁾	19.4	8	237	T38 795-1676
	T45 rods ²⁾	25	8	275	T45 795-1681
	T51 rods ²⁾	27	15	285	T51 795-1690
	ST58 tubes	39	21	318	ST58 795-2606
	GT60 rods	50	19.6	500	GT60 795-2604
	ST68 tubes	46	28	318	ST68 795-2605

¹⁾ Without flushing hole
²⁾ With flushing hole

THREAD GREASE	DIMENSIONS			PART NO.	
	D (mm)	L (mm)	Weight (kg)		
	For integral drill steels and shank rods				
	Can	215	170	4.5	795-1960
	Can	300	380	18	795-1961
	Tube	53/57	235	0.4	795-1962
	Low temp. Can	300	380	18	795-1963
	Barrel	610	870	240	795-1964
	Barrel	-	-	50	795-1967
	Steel can	300	372	18	795-1969

BIT DIAMETER WEAR GAUGE

FOR MEASURING DIAMETER ON DRILL BITS

Measures bit diameter from 40,6 mm to 53,6 mm in steps of 0,2mm.
Partno: 795-1310



BIT CLASSIFICATION - SYMBOL EXPLANATION



1. These bits are designed to deliver maximum penetration rates. They tend to work best in soft to medium-hard (up to 150 MPa) and non-abrasive rock formations.
2. These bits are designed to deliver maximum penetration rates. They tend to work best in soft to medium-hard (up to 150 MPa) and non-abrasive rock formations.
3. These bits offer a balance between penetration rate and bit service life. They will drill fast, while still delivering rock tool economy in a wide range of rock conditions.
4. These bits offer a balance between penetration rate and bit service life. They will drill fast, while still delivering rock tool economy in a wide range of rock conditions.
5. These bits are optimized to provide the best possible rock tool economy through long service life. This is especially true and important in hard and abrasive rock formations (above 20 percent silica).

CODE KEY INTEGRAL DRILL STEELS

7XX-YYZZ-QQ

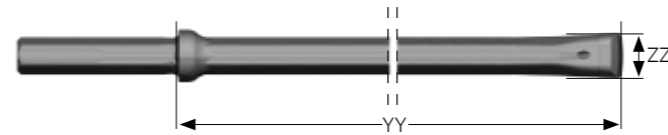

MAIN CODE 7XX	SUB CODE YYZZ	3RD CODE GROUP QQ
714 = 22x108 shank, Hex 22 chisel	YY = effective length in dm ZZ = insert diameter in mm	50 = insert height 17 mm 65 = insert height 19 mm
724 = 19x108 shank, Hex 19 chisel	YY = effective length in dm ZZ = insert diameter in mm	
728 = 22x108 shank, Hex 19 chisel	YY = effective length in dm ZZ = insert diameter in mm	

CODE KEY TAPERED BITS

7XXX-YYZZ-QQ



MAIN CODE 7XXX	SUB CODE YYZZ	3RD CODE GROUP QQ
7770 = 12 deg Long skirt	YY = 19, 3 gauge buttons	
7776 = 11 deg	YY = 44/52 Normal, 5 gauge buttons	(Q) = B ballistic buttons
7788 = 7 deg	YY = 54, 6 gauge buttons	
7795 = 12 deg Short skirt	YY = 64 Normal, 4 gauge buttons YY = 90 Cross bit HD	QQ = 42 CC-grade 442 (inserts) QQ = 48 CC-grade XT48 (buttons)
	ZZ = Bit diameter in mm	

CODE KEY TAPERED RODS

7XXX-YYZZ-QQ

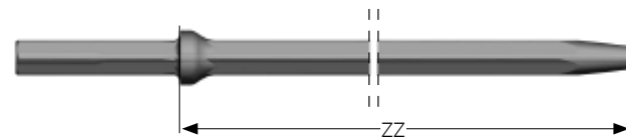

MAIN CODE 7XXX	SUB CODE YYZZ	3RD CODE GROUP QQ
7870 = 12 deg	YY = 11 HF hardened, Sanbar 20	11 = no packing
7876 = 11 deg	YY = 51 HF hardened, Sanbar 61	
7888 = 7 deg	YY = 61 Carburized, Sanbar 64	
	ZZ = effective length in dm	

CODE KEY EXTENSION RODS

7XXX-YYZZ-QQ

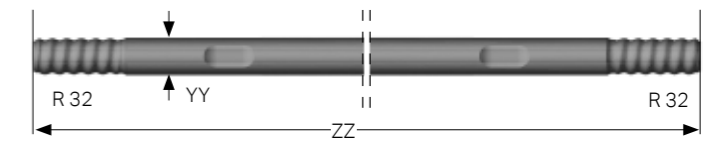

MAIN CODE 7XXX	SUB CODE YYZZ	3RD CODE GROUP QQ
7851 = R22	YY = 13 Hex 22	20 = Carburized
7852 = R25	YY = 23 Hex 25	30 = HF-hardened
7853 = R32	YY = 33 Round 33	
7854 = R38	YY = 43 Round 39	
7857 = R23	ZZ = effective length in dm	
7324 = T38	YY = 43 Round 39	20 = Carburized
7325 = T45	YY = 73 Round 46	30 = HF-hardened
7326 = T51	YY = 53 Round 52	
	ZZ = effective length in dm	

CODE KEY MF RODS

7XXX-YYZZ-QQ

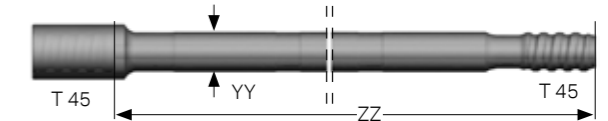

MAIN CODE 7XXX	SUB CODE YYZZ	3RD CODE GROUP QQ
7853 = R32	YY = 48 Hex 22	20 = Carburized
7857 = R23	YY = 51 Round 32	
	ZZ = approximate length in dm	
7324 = T38	YY = 47 Round 39	20 = Carburized
7325 = T45	YY = 77 Round 46	70 = Sandvik Tough
7326 = T51	YY = 55 Round 52	80 = +Range
7327 = T35	YY = 11 Round 60	
7610 = GT60	YY = 14 Round 60, for 92 mm bits	
	ZZ = effective length in dm	

CODE KEY DRIFTER RODS

7XXX-YYZZ-Q

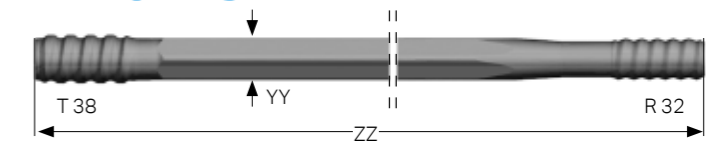

MAIN CODE 7XXX	SUBCODE YY		3RD CODE GROUP Q
	Code	Steel Section	
			ZZ = approximate length in dm
7853 = R32 shank end	24	Hex 25	R25 20 = Carburized
7854 = R38 shank end	30	Hex 28	R25
7324 = T38 shank end	76	Hex 28	R28
7327 = T35 shank end	87	Hex 32	R28
	65	MF-drifter Hex 35	R32
	86	Hex 32	R32
	96	Hex 35	R32
	67	Hex 35	α330
	70	Round 39	α330
	72	Round 39	R35
	85	Hex 35	R35
	52	MF-drifter Round 39	R35

CODE KEY SHANK RODS

7XXX-YYZZ-QQ

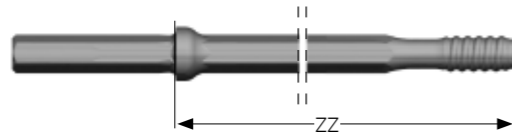

MAIN CODE 7XXX	SUB CODE YYZZ	3RD CODE GROUP QQ
7801 = R22	Shank rods:	Shank rods:
7802 = R25	YY = 61 Hex 22	11 = shank H22×108, no packing
7803 = R32	YY = 71 Hex 25	21 = shank H25×159, no packing
	ZZ = effective length in dm	30 = shank H25×108, no packing
7807 = R23		
7859 = R28		

CODE KEY SHANK ADAPTERS

7XXX-YYZZ-QQ



MAIN CODE 7XXX	FEATURES QQ
7801 = R22	01, 02, 03= Separate flushing
7802 = R25	05= Improved surface on splines
7803 = R32	12= Shank for CLS rock drill
7804 = R38	15= Shank for CLS rock drill with improved surface on splines
7807 = R23	19= 19mm packing
7859 = R28	23= 23mm packing
7304 = T38	30= 10mm packing
7305 = T45	80 = 16 mm packing
7306 = T51	40= 11mm packing
7307 = T35	50= 12.7mm packing
7328 = ST58	60/61= 14mm packing
7329 = ST68	80= 16mm packing
7340 = LT90	P-15= shank for rock pulse
7600 = GT60	85= +Range shank

CODE KEY DRILL TUBES / GUIDE TUBES

7XXX-YYZZ-QQ



MAIN CODE 7XXX	SUB CODE YYZZ	3RD CODE GROUP QQ
7953 = R32 guide tube	YY = diameter in mm	20, 21 = Carburized
7955 = T38 guide tube	ZZ = approximate length in dm	26 = Carburized, Shoulder-Bottom drive, Oiled
7956 = T45 guide tube		46 = Carburized, Shoulder-Bottom drive, Back flow valve, Oiled
7957 = T51 guide tube		70 = Sandvik Tough
7985 = T45 drill tube		80 = Plus range
7378 = ST58 drill tube		
7379 = ST68 drill tube		
7640 = GT60 pilot tube		
7660 = GT60 drill tube		

CODE KEY DRIFTER BITS

7XXX-YYZZ-(Q) QQ



MAIN CODE 7XXX	SUB CODE YYZZ	3RD CODE GROUP QQ
7731 = R22	YY = 10 Cross bit Normal	(Q) = S spherical buttons
7732 = R25	YY = 13/14 Cross bit HD	(Q) = R ballistic buttons
7733 = R32	YY = 16 Normal bit with 6 gauge buttons	(Q) = C conical buttons
7737 = R23	YY = 44 Normal bit 5 gauge buttons	
7738 = R35	YY = 52 HD bit 5 gauge buttons	QQ = 11 CC-grade 411 (inserts)
7739 = R28	YY = 53 Normal bit 6 gauge buttons	QQ = 42 CC-grade 442 (inserts)
7764 = α250	YY = 54 Normal bit 6 gauge buttons	QQ = 48 CC-grade XT48 (buttons)
7767 = α330	YY = 55 Normal bit 6 gauge buttons	QQ = 55 CC-grade DP55 (buttons)
	ZZ = Bit diameter in mm	QQ = 65 CC-grade DP65 (buttons)

CODE KEY BIG THREADED BITS

7XXX-YYZZ-(Q) QQ



MAIN CODE 7XXX	SUB CODE YYZZ	3RD CODE GROUP QQ
7734 = R38	YY = 16 HD bit 6 gauge buttons	(Q) = S spherical buttons
7514 = T38	YY = 18 HD bit 8 gauge buttons	(Q) = R ballistic buttons
7515 = T45	YY = 19 HD bit 9 gauge buttons	(Q) = C conical buttons
7516 = T51	YY = 26 Button bit Normal	QQ = 11 CC-grade 411 (inserts)
7517 = T35	YY = 38 Button bit HD	QQ = 42 CC-grade 442 (inserts)
7620 = GT60	YY = 40 HD X-bit	QQ = 48 CC-grade XT48 (buttons)
	YY = 46 HD Retrac bit 6 gauge buttons	QQ = 55 CC-grade DP55 (buttons)
	YY = 48 HD Retrac bit 8 gauge buttons	QQ = 60 CC-grade (conical buttons)
	YY = 49 HD Retrac bit 9 gauge buttons	QQ = 65 CC-grade DP65 (buttons)
	YY = 78 Retrac bit with buttons	
	YY = 55	
	YY = 75	
	ZZ = Bit diameter in mm	

CODE KEY COUPLINGS

7XXX-YYZZ

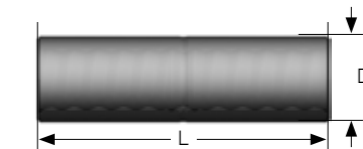

MAIN CODE 7XXX	SUB CODE YYZZ
7991 = R22	YY = 04 R28 adapter thread
7992 = R25	YY = 20 Tough hardened, same thread both ends, no middlestop
7993 = R32	YY = 24 R25 adapter thread
7994 = R38	YY = 33 Tough hardened, same thread both ends, with middlestop
7314 = T38	YY = 34 R32 adapter thread
7315 = T45	YY = 36 Carburized, same thread both ends, with middlestop
7316 = T51	YY = 44 R38 adapter thread
7317 = T35	YY = 41 T38 adapter thread
	YY = 62 T45 adapter thread
	YY = 35 R32 adapter thread, full bridge
	ZZ = Outer diameter in mm

CODE KEY BIT ADAPTERS

7XXX-YY01

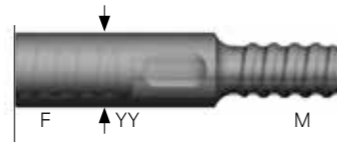

MAIN CODE 7XXX

7832 = R25 internal thread
7833 = R32 internal thread
7834 = R38 internal thread
7837 = R23 internal thread
7839 = R28 internal thread
7334 = T38 internal thread
7335 = T45 internal thread
7336 = T51 internal thread
7337 = T35 internal thread

SUB CODE YY

YY = 33 R32 external thread
YY = 43 R38 external thread
YY = 44 T38 external thread
YY = 54 T45 external thread
YY = 64 T51 external thread

LET US MAKE YOUR GRINDING MORE PROFITABLE

We offer a wide range of high quality grinding machines, grinding wheels and cups. Every product is specifically designed to increase safety, productivity and – not least – revenue. They all work perfectly with the TH, DTH, integral steels and cross and X-bits. We know that every customer has their own specific challenges that require different solutions.

This is why we offer products which are suitable for all conceivable situations – from grinding directly at the drill rigs, to grinding in workshops for high levels of production. We also offer spare parts, as well as all the support you need to create a safe and successful mining and construction business.

RG100E INTEGRAL STEEL GRINDER	96
RG100H INTEGRAL STEEL GRINDER	97
RG100P INTEGRAL STEEL GRINDER	98
RG140P INTEGRAL STEEL AND CROSS GRINDER	99
RG400 BUTTON BIT GRINDER	100
RG410 BUTTON BIT GRINDER	101
RG420E BUTTON BIT GRINDER	102
RG420H BUTTON BIT GRINDER	103
RG440 BUTTON BIT GRINDER	104
RG460 BUTTON BIT GRINDER	105
RG470 PRO BUTTON BIT GRINDER	106
RG510 WATER CIRCULATION UNIT	107
RG520 DUST EXHAUST UNIT	108
GRINDING WHEELS	109
GRINDING CUPS	111
GRINDING ACCESSORIES	112

RG100E

INTEGRAL STEEL GRINDER

GRINDING APPLICATIONS

Mobile, lightweight, electrical grinder. Intended for frontal and gauge grinding of chisel integral steels.

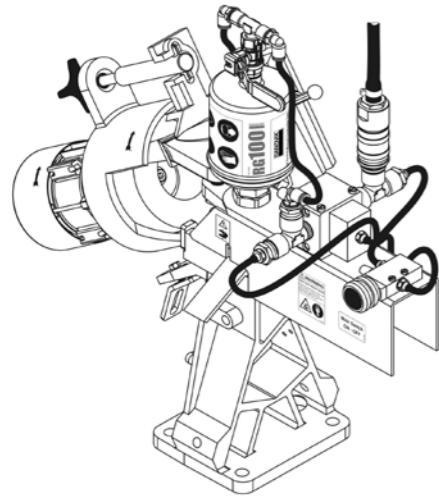

TECHNICAL DATA

Air pressure	Max 8 bar
Air consumption	5–10 l/sec
Rated power (motor)	1.1 kW
Idling speed	2800 (50 Hz) RPM/ 3400 (60 Hz) RPM
Hose connections:	
Air, air hose	9.5 mm (3/8")
Water, water hose	9.5 mm (3/8")
Dimensions: H x W x D	611 x 550 x 350 mm
Grinding wheel dimensions	127 x 546 x 321 mm
Weight inclusive of grinding wheel	21.5 kg
Cutting-edge radius	80 mm
Cutting-edge angle	110°

PART. NO FOR MACHINES

Complete grinder, hydraulic powered 796-5320-XX*
*For two last digits, see table below, under "Code"

VOLTAGE/PHASE ALT.

Voltage	Phases	Hz	Code
220–240 V	1	50/60 Hz	50
380–420 V	3	50/60 Hz	52
220–240 V	3	50/60 Hz	59

ACCESSORIES (INCLUDED IN MACHINE DELIVERY)

Grinding wheel for dry grinding	797-1227-15
Protective goggles	797-5771
T-hexagon wrench	797-5766-06

ACCESSORIES (OPTIONAL)

Grinding wheel (dry grinding)	797-1227-15
Grinding wheel (wet grinding)	797-1227-10
Kit for grinding plug hole drill steels	797-5489-50
Mounting bracket (for drill rig)	797-5330-91
Support for integral steels	797-5330-92
Grinding template for chisel bit	795-1343
Grinding template for plug hole steels	795-1336

RECOMMENDED LUBRICANTS

Grease, 0.42 kg cartridge 797-5773-22

GRINDING WHEEL DIMENSIONS

D	= 127 mm
W	= 63 mm
d	= 32 mm
D1	= 80 mm
w	= 50 mm

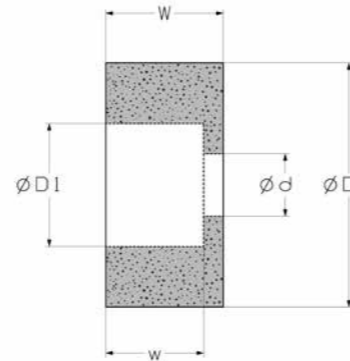

RG100H

INTEGRAL STEEL GRINDER

GRINDING APPLICATIONS

Mobile, lightweight, hydraulic grinder. Intended for frontal and gauge grinding of chisel integral steels.

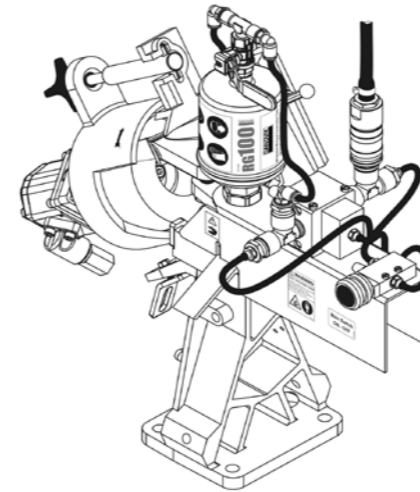

TECHNICAL DATA

Hydraulic pressure	Max 200 bar/Min. 140 bar
Oil flow consumption	12 l/min
Air pressure	Max 8 bar
Air consumption	5–10 l/sec
Rated power (motor)	4 kW
Idling speed	3700 RPM
Hose connections:	
Hydraulic, hydraulic hose	R 3/8" female thread
Air, air hose	9.5 mm (3/8")
Water, water hose	9.5 mm (3/8")
Dimensions: H x W x D	600 x 550 x 350 mm
Grinding wheel dimensions	127 x 63 x 32 mm
Weight inclusive of grinding wheel	15.5 kg
Cutting-edge radius	80 mm
Cutting-edge angle	110°

PART. NO FOR MACHINES

Complete grinder, hydraulic powered 796-5330

ACCESSORIES (INCLUDED IN MACHINE DELIVERY)

Grinding wheel for dry grinding	797-1227-15
Protective goggles	797-5771
T-hexagon wrench	797-5766-06

ACCESSORIES (OPTIONAL)

Grinding wheel (dry grinding)	797-1227-15
Grinding wheel (wet grinding)	797-1227-10
Kit for grinding plug hole drill steels	797-5489-50
Mounting bracket (for drill rig)	797-5330-91
Support for integral steels	797-5330-92
Grinding template for chisel bit	795-1343
Grinding template for plug hole steels	795-1336

RECOMMENDED LUBRICANTS

Grease, 0.42 kg cartridge 797-5773-2

GRINDING WHEEL DIMENSIONS

D	= 127 mm
W	= 63 mm
d	= 32 mm
D1	= 80 mm
w	=

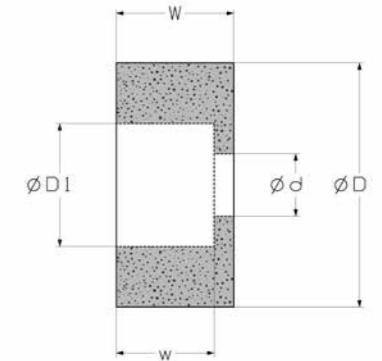

RG100P

INTEGRAL STEEL GRINDER

GRINDING APPLICATIONS

Mobile, lightweight, pneumatic grinder. Intended for frontal and gauge grinding of chisel integral steels.

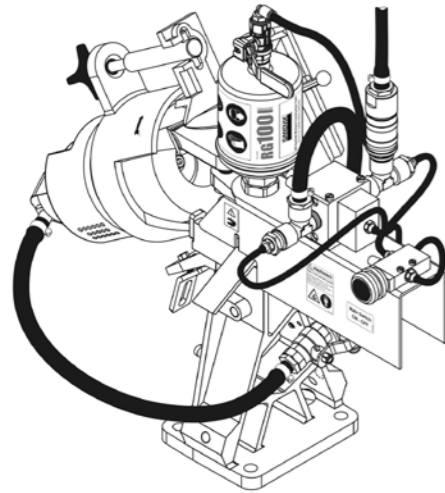

TECHNICAL DATA

Air pressure	Max 8 bar/min 6 bar
Air consumption	40–60 l/sec
Rated power (motor)	1.7 kW
Idling speed	4900 RPM
Hose connection:	
Air, air hose	12.5 mm (1/2")
Air or water hose for cooling	9.5 mm (3/8")
Dimensions: H × W × D	660 × 550 × 350 mm
Grinding wheel dimensions	127 × 63 × 32 mm
Weight inclusive of grinding wheel	18.5 kg
Cutting-edge radius	80 mm
Cutting-edge angle	110°

PART. NO FOR MACHINES

Grinder, air powered 796-5300

ACCESSORIES (INCLUDED IN MACHINE DELIVERY)

Grinding wheel for dry grinding 797-1227-15
 Protective goggles 797-5771
 T-hexagon wrench 797-5766-06
 Support bracket 797-5289

ACCESSORIES (OPTIONAL)

Grinding wheel (dry grinding) 797-1227-15
 Grinding wheel (wet grinding) 797-1227-10
 Kit for grinding plug hole drill steels 797-5489-50
 In line oiler 797-5747-50
 Mounting bracket (for drill rig) 797-5330-91
 Support for integral steels 797-5330-92
 Grinding template for chisel bit 795-1343
 Grinding template for plug hole steels 795-1336

RECOMMENDED LUBRICANTS

Air tool oil, 1 liter 797-5870-90
 Grease, 0.42 kg cartridge 797-5773-22

GRINDING WHEEL DIMENSIONS

D = 127 mm
 W = 63 mm
 d = 32 mm
 D1 = 80 mm
 w = 50 mm

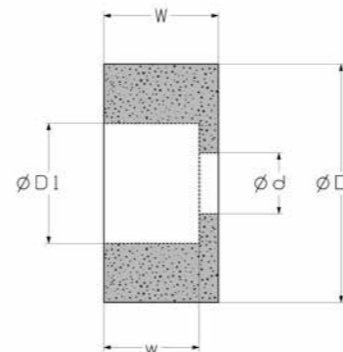

RG140P

INTEGRAL STEEL GRINDER AND CROSS GRINDER

GRINDING APPLICATIONS

Basic pneumatic grinder intended for frontal and gauge grinding of integral steels (with straight grinding wheel) or cross and X-bits (with angled grinding wheel). The machine is suitable for bit sizes: Integral steels, all diameters. Cross bits Ø 33–43 mm.

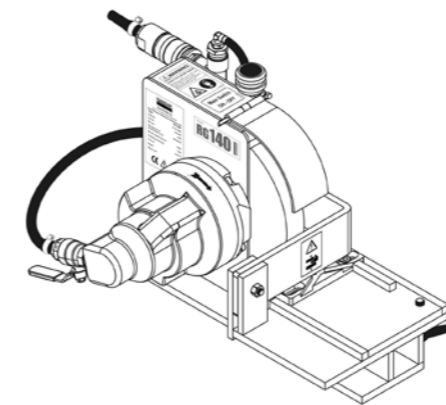

TECHNICAL DATA

Air pressure	Max 8 bar/min 6 bar
Air consumption	40–60 l/sec
Rated power (motor)	1.7 kW
Idling speed	3000 RPM
Hose connection:	
Air, air hose	12.5 mm (1/2")
Dimensions: H × W × D	505 × 276 × 326 mm
Grinding wheel dimensions:	
Grinding wheel, 132°	200 × 28 × 32 mm
Grinding wheel, straight	200 × 32 × 32 mm
Weight inclusive of grinding wheel	22 kg

PART. NO FOR MACHINES

Grinder, air powered 796-3800

ACCESSORIES (INCLUDED IN MACHINE DELIVERY)

Grinding wheel, for 90° cross bits (bit size: Ø 33–43, for dry grinding) 797-1185-28*
 Grinding wheel dresser 796-1858
 Protective goggles 797-5771
 T-hexagon wrench 797-5766-06
 Dressing template for 4-inserts (for 90° cross bits) 797-6035-06

ACCESSORIES

(NOT INCLUDED, TO BE ORDERED SEPARATELY)

Grinding wheel, straight for gauge grinding (for dry grinding) 797-1101-32**
 Grinding wheel, for 90° cross bits (bit size: Ø 33–39, for dry grinding) 797-1101-25

ACCESSORIES (OPTIONAL)

Spare rollers for wheel dresser 796-1867
 In line oiler 797-5747-50
 Mounting bracket (for drill rig) 797-5330-91

RECOMMENDED LUBRICANTS

Air tool oil, 1 liter 797-5870-90
 Grease, 0.42 kg cartridge 797-5773-22

GRINDING WHEEL DIMENSIONS*

D = 200 mm
 W = 28 mm
 d = 32 mm

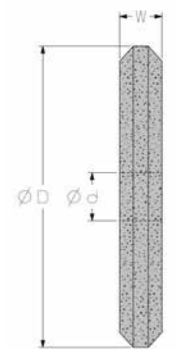

GRINDING WHEEL DIMENSIONS**

D = 200 mm
 W = 32 mm
 d = 32 mm

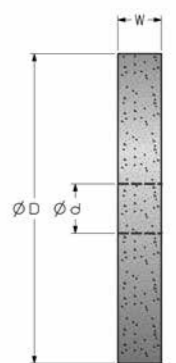

RG400

BUTTON BIT GRINDER

GRINDING APPLICATIONS

Handheld, lightweight, lower-powered pneumatic grinder intended for all kinds of button bits with max button size of 10 mm.

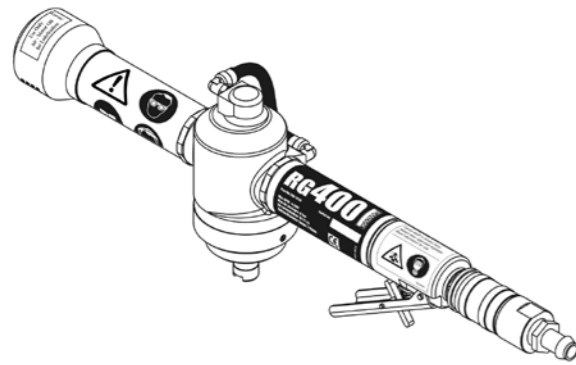

TECHNICAL DATA

Air supply pressure	Max 8 bar/min 6 bar
Air consumption	16–17 l/sec
Spindle speed	14000 RPM
Flushing air pressure	Max. 6 bar
Flushing water pressure	Max. 6 bar
Water consumption	5–6 l/min
Hose connections:	
Air, air hose	12.5 mm (1/2")
Water, water hose	6.3 mm (1.4")
Dimensions: H × W × D	156 × 533 × 84 mm
Weight	2.9 kg

PART. NO FOR MACHINES

Complete grinder 796-5116

ACCESSORIES (INCLUDED IN MACHINE DELIVERY)

O-ring	797-5888-24
Hose, 6/4 mm	797-5957-06
Connector, 6-1/4"	797-5899-13
Nylon packing, 1/4"	797-5934-13
House Nipple, 1/4"-R1/4"	797-5777-13
Plug 6, R9 6 mm	797-5769-06
Screw (to remove damper)	797-5463-31
Shock Absorber	797-5273-01

ACCESSORIES (OPTIONAL)

Tools for O-ring replacement	797-5452
In line oiler	797-5747-50
Cooling/tank unit, complete	797-5488-85
Grinding cups	see page 20
Grinding template	see page 21

RECOMMENDED LUBRICANTS

Air tool oil, 1 liter 797-5870-90

RG410

BUTTON BIT GRINDER

GRINDING APPLICATIONS

Handheld, lightweight, higher-powered pneumatic grinder intended for all kinds of button bits.

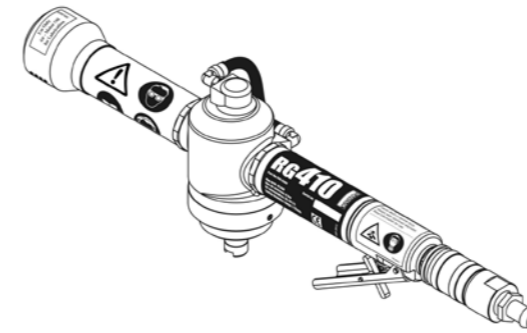

TECHNICAL DATA

Air supply pressure	Max 8 bar/min 6 bar
Air consumption	40–55 l/sec
Spindle speed	19000 RPM
Flushing air pressure	Max. 6 bar
Flushing water pressure	Max. 6 bar
Water consumption	5–6 l/min
Hose connections:	
Air, air hose	12.5 mm (1/2")
Water, water hose	6.3 mm (1.4")
Dimensions: H × W × D	156 × 533 × 84 mm
Weight	2.9 kg

PART. NO FOR MACHINES

Complete grinder 796-5100

ACCESSORIES (INCLUDED IN MACHINE DELIVERY)

O-ring	797-5888-24
Hose, 6/4 mm	797-5957-06
Connector, 6-1/4"	797-5899-13
Nylon packing, 1/4"	797-5934-13
House Nipple, 1/4"-R1/4"	797-5777-13
Plug 6, R9 6 mm	797-5769-06
Screw (to remove damper)	797-5463-31
Shock Absorber	797-5273-01

ACCESSORIES (OPTIONAL)

Tools for O-ring replacement	797-5452
In line oiler	797-5747-50
Cooling/tank unit, complete	797-5488-85
Grinding cups	see page 20
Grinding template	see page 21

RECOMMENDED LUBRICANTS

Air tool oil, 1 liter 797-5870-90

RG420E

BUTTON BIT GRINDER

GRINDING APPLICATIONS

Stationary electrical grinder for workshops, or to be mounted onto drill rigs. Intended for all kinds of button bits. Bit holder suitable for diameters of up to Ø 122 mm: Top hammer (TH) button bits (normal skirt) up to Ø 152 mm, TH button bits (Retrac skirt) up to Ø 127 mm and down the hole button bits up to Ø 200 mm (max. shank Ø 110 mm and max. head length 110 mm).

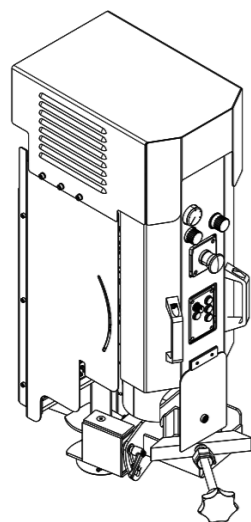

TECHNICAL DATA

Air supply pressure	Max 10 bar/min 6 bar
Air consumption	0.5–3 l/sec
Water supply pressure	Max 8 bar/min 3.5 bar
Water consumption (cooling tank)	2–4 l/min
Water consumption (pump)	0.2–1 l/min
Coolant/flushing medium	Water
Rated power (motor)	1.5 kW
Air connection, air hose	9.5 mm (3/8")
Water connection, water hose	9.5 mm (3/8")
Dimensions: H × W × D	730 × 390 × 390 mm
Weight	45 kg

PART. NO FOR MACHINES

Grinder with cover	796-6215-XX*
Grinder with pump and cover	796-6265-XX*

*For two last digits, see table below, under "Code"

VOLTAGE/PHASE ALT.

Voltage	Phases	Hz	Code
220–240 V	1	50/60 Hz	50
380–420 V	3	50/60 Hz	52
220–240 V	3	50/60 Hz	59
440 V	3	60 Hz	63

ACCESSORIES (INCLUDED IN MACHINE DELIVERY)

Bit insert	797-5502-26
O-ring for Grinding cup	797-5888-24
Assembly tools for O-ring replacement	797-5452
Lock plate	797-5502-39
Spindle tool 9 mm	797-5464-07
Grease gun	797-5870-20

ACCESSORIES (OPTIONAL)

Bit Mandrels	797-5348-XX**
**23 = R23, 25 = R25, 28 = R28, 32 = R32, 33 = R33, 35 = R35, 38 = R28/T38, 45 = T45, 51 = T51, 58 = ST58, 60 = GT60, 68 = ST68	
Example: Bit mandrel R32 = 797-5348-32	
Grinding cups	see page 20
Grinding template	see page 21

SPARE PART KITS

Complete Grinding head (8000 (50Hz) – 9500 (60Hz)) RPM including flushing head	797-5140
Complete Grinding head (13000 (50Hz) – 15000 (60Hz)) RPM including flushing head	797-5130
All bearings, seals and screws for grinding head	797-5463-05
Outer Spindle (for Flushing head)	797-5464-02
Complete flushing head	797-5464-63 ¹ 797-5464-62 ²
Small kit for flushing head	797-5464-44 ¹ 797-5464-45 ²
Big kit for flushing head	797-5464-59 ¹ 797-5464-60 ²

- 1 = Non lubrication
- 2 = Lubrication

RECOMMENDED LUBRICANTS

Gear oil, 1 liter	797-5870-15
Air tool oil, 1 liter	797-5870-90
Grease, 0.42 kg cartridge	797-5773-22

RG420H

BUTTON BIT GRINDER

GRINDING APPLICATIONS

Stationary hydraulic grinder for workshops, or to be mounted onto drill rigs. Intended for all kinds of button bits. Bit holder holds diameters up to Ø 122 mm: Top hammer (TH) button bits (normal skirt) up to Ø 152 mm, TH button bits (Retrac skirt) up to Ø 127 mm and down the hole button bits up to Ø 165 mm (max. shank Ø 110 mm and max. head length 110 mm).

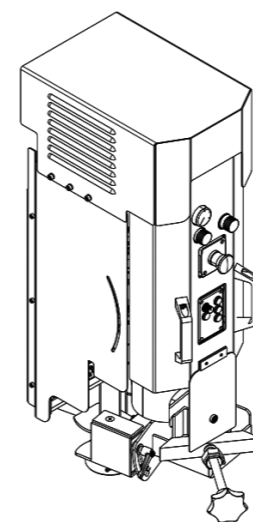

TECHNICAL DATA

Air supply pressure	Max 10 bar/min 6 bar
Air consumption	0.5–3 l/sec
Water supply pressure	Max 8 bar/min 3.5 bar
Water consumption (cooling tank)	2–4 l/min
Water consumption (pump)	0.2–1 l/min
Coolant/flushing medium	Water
Rated power (motor)	2.8–4 kW
Air connection, air hose	9.5 mm (3/8")
Water connection, water hose	9.5 mm (3/8")
Hydraulic connection, hydraulic hose	R3/8" female thread
Dimensions: H × W × D	730 × 390 × 390 mm
Weight	40 kg
Electricity supply	24V DC, 5A
Hydraulic Supply pressure	Max 200 bar/Min 140 bar
Hydraulic-oil flow	12 l/min

PART. NO FOR MACHINES

Grinder with cover	796-6235
Grinder with pump and cover	796-6285
Grinder with tank and cover	796-6236

ACCESSORIES (INCLUDED IN MACHINE DELIVERY)

Bit insert	797-5502-26
O-ring for Grinding cup	797-5888-24
Assembly tools for O-ring replacement	797-5452
Lock plate	797-5502-39
Spindle tool 9 mm	797-5464-07
Grease gun	797-5870-20

ACCESSORIES (OPTIONAL)

Bit Mandrels	797-5348-XX**
**23 = R23, 25 = R25, 28 = R28, 32 = R32, 33 = R33, 35 = R35, 38 = R28/T38, 45 = T45, 51 = T51, 58 = ST58, 60 = GT60, 68 = ST68	
Example: Bit mandrel R32 = 797-5348-32	
Grinding cups	see page 20
Grinding template	see page 21

SPARE PART KITS

Complete Grinding head (8000 (50Hz) – 9500 (60Hz)) RPM including flushing head	797-5140
Complete Grinding head (13000 (50Hz) – 15000 (60Hz)) RPM including flushing head	797-5130
All bearings, seals and screws for grinding head	797-5463-05
Outer Spindle (for Flushing head)	797-5464-02
Complete flushing head	797-5464-63 ¹ 797-5464-62 ²
Small kit for flushing head	797-5464-44 ¹ 797-5464-45 ²
Big kit for flushing head	797-5464-59 ¹ 797-5464-60 ²

- 1 = Non lubrication
- 2 = Lubrication

RECOMMENDED LUBRICANTS

Gear oil, 1 liter	797-5870-15
Air tool oil, 1 liter	797-5870-90
Grease, 0.42 kg cartridge	797-5773-22

RG440

BUTTON BIT GRINDER

GRINDING APPLICATIONS

Stationary electrical grinder for workshops. Intended for all top hammer (TH) button bits. Bit holder suitable for Bits with diameters of up to Ø 102 mm: TH button bits (normal skirt) up to Ø 152 mm, TH button bits (retrac skirt) up to Ø 102 mm.

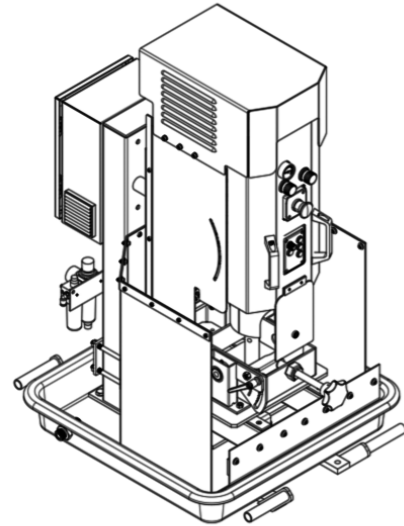

TECHNICAL DATA

Air supply pressure	Max 10 bar/min 6 bar
Air consumption	0.5–3 l/sec
Water supply pressure	Max 8 bar/min 3 bar
Water consumption	0.2–1 l/min
Coolant/flushing medium	Water
Rated power (motor)	1.5 kW
Air connection, air hose	9.5 mm (3/8")
Water connection, water hose	9.5 mm (3/8")
Dimensions: H × W × D	750 × 670 × 795 mm
Weight	95 kg

PART. NO FOR MACHINES

Grinder with cover	796-6005-XX*
Grinder with pump and cover	796-6055-XX*

*For two last digits, see table below, under "Code"

VOLTAGE/PHASE ALT.

Voltage	Phases	Hz	Code
220–240 V	1	50/60 Hz	50
380–420 V	3	50/60 Hz	52
220–240 V	3	50/60 Hz	59
440 V	3	60 Hz	63

ACCESSORIES (INCLUDED IN MACHINE DELIVERY)

T38/R38 Bit Mandrel	797-5348-38
O-ring for Grinding cup	797-5888-24
Assembly tools for O-ring replacement	797-5452
Lock plate	797-5502-39
Spindle tool 9 mm	797-5464-07
Grease gun	797-5870-20

ACCESSORIES (OPTIONAL)

Bit Mandrels	797-5348-XX**
**23 = R23, 25 = R25, 28 = R28, 32 = R32, 33 = R33, 35 = R35, 38 = R28/T38, 45 = T45, 51 = T51, 58 = ST58, 60 = GT60, 68 = ST68	
Example: Bit mandrel R32 = 797-5348-32	
Grinding cups	see page 20
Grinding template	see page 21

SPARE PART KITS

Complete Grinding head (8000 (50Hz) – 9500 (60Hz)) RPM including flushing head	797-5140
Complete Grinding head (13000 (50Hz) – 15000 (60Hz)) RPM including flushing head	797-5130
All bearings, seals and screws for grinding head	797-5463-05
Outer Spindle (for Flushing head)	797-5464-02
Complete flushing head	797-5464-63 ¹ 797-5464-62 ²
Small kit for flushing head	797-5464-44 ¹ 797-5464-45 ²
Big kit for flushing head	797-5464-59 ¹ 797-5464-60 ²

RECOMMENDED LUBRICANTS

Gear oil, 1 litre	797-5870-15
Air tool oil, 1 litre	797-5870-90
Grease, 0.42 kg cartridge	797-5773-22

RG460

BUTTON BIT GRINDER

GRINDING APPLICATIONS

Stationary electrical grinder for workshops. Intended for all down the hole (DTH) button bits. Bit holder suitable for diameters up to Ø 106 mm: DTH button bits up to Ø 178 mm (max. shank Ø 106 mm and max. head length 92 mm).

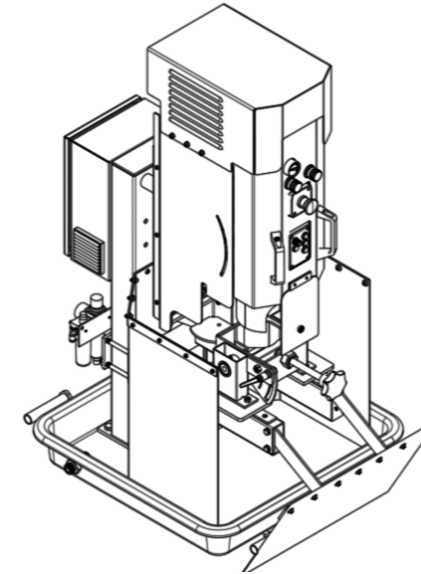

TECHNICAL DATA

Air supply pressure	Max 10 bar/min 6 bar
Air consumption	0.5–3 l/sec
Water supply pressure	Max 8 bar/min 3 bar
Water consumption	0.2–1 l/min
Coolant/flushing medium	Water
Rated power (motor)	1.5 kW
Air connection, air hose	9.5 mm (3/8")
Water connection, water hose	9.5 mm (3/8")
Dimensions: H × W × D	990 × 670 × 795 mm
Weight	95 kg

PART. NO FOR MACHINES

Grinder with cover	796-6105-XX*
Grinder with pump and cover	796-6155-XX*

*For two last digits, see table below, under "Code"

VOLTAGE/PHASE ALT.

Voltage	Phases	Hz	Code
220–240 V	1	50/60 Hz	50
380–420 V	3	50/60 Hz	52
220–240 V	3	50/60 Hz	59
440 V	3	60 Hz	63

ACCESSORIES (INCLUDED IN MACHINE DELIVERY)

T38/R38 Bit Mandrel	797-5348-38
O-ring for Grinding cup	797-5888-24
Assembly tools for O-ring replacement	797-5452
Lock plate	797-5502-39
Spindle tool 9 mm	797-5464-07
Grease gun	797-5870-20
Insert plate DTH, 3"	797-5503-73
Insert plate DTH, 4"	797-5503-74
Insert plate DTH, 5"	797-5503-75
Insert plate DTH, 6"	797-5503-76

ACCESSORIES (OPTIONAL)

Grinding cups	see page 20
Grinding template	see page 21

SPARE PART KITS

Complete Grinding head (8000 (50Hz) – 9500 (60Hz)) RPM including flushing head	797-5140
Complete Grinding head (13000 (50Hz) – 15000 (60Hz)) RPM including flushing head	797-5130
All bearings, seals and screws for grinding head	797-5463-05
Outer Spindle (for Flushing head)	797-5464-02
Complete flushing head	797-5464-63 ¹ 797-5464-62 ²
Small kit for flushing head	797-5464-44 ¹ 797-5464-45 ²
Big kit for flushing head	797-5464-59 ¹ 797-5464-60 ²

- 1 = Non lubrication
- 2 = Lubrication

RECOMMENDED LUBRICANTS

Gear oil, 1 liter	797-5870-15
Air tool oil, 1 liter	797-5870-90
Grease, 0.42 kg cartridge	797-5773-22

RG470 PRO

BUTTON BIT GRINDER

GRINDING APPLICATIONS

Highly efficient stationary electrical grinder for workshops. Intended for all button bits. Top Hammer (TH) bits Ø 28 mm (bit length > 65 mm) up to Ø 152 mm, and down the hole (DTH) bits Ø 90 mm up to Ø 270 mm.

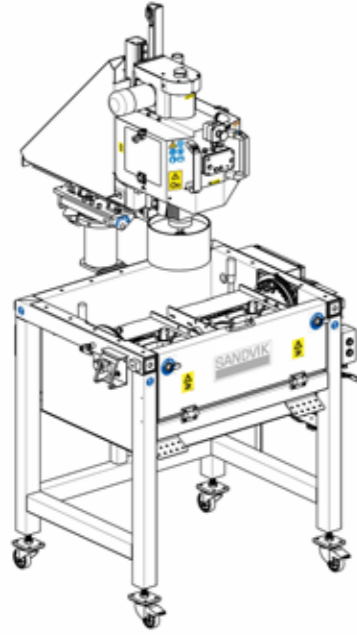

TECHNICAL DATA

Air supply pressure	Max 10 bar/min 6 bar
Air consumption	0.5 – 2 l/sec
Water supply pressure	Max 8 bar/min 3.5 bar
Water consumption	1 l/min
Coolant/flushing medium	Water
Rated power (grinding motor)	3 kW
Air connection, air hose	9.5 mm (3/8")
Water connection, water hose	9.5 mm (3/8")
Dimensions: H x W x D	2290 x 1337 x 1422 mm
Weight	320 kg

PART. NO FOR MACHINES

Grinder 796-6600-XX*

*For two last digits, see table below, under "Code".

VOLTAGE/PHASE ALT.

Voltage	Phases	Hz	Code
380–420 V	3	50/60 Hz	52
220–240 V	3	50/60 Hz	59

ACCESSORIES (INCLUDED IN MACHINE DELIVERY)

O-ring for Grinding cup	797-5888-24
Assembly tools for O-ring replacement	797-5452
Spindle tool 9 mm	797-5464-07
Grease gun	797-5870-20

ACCESSORIES (OPTIONAL)

Grinding cups	see page 20
Grinding template	see page 21

SPARE PART KITS

Outer Spindle (for flushing head)	797-5464-02
Complete flushing head	797-5464-63 ¹ 797-5464-62 ²
Small kit for flushing head	797-5464-44 ¹ 797-5464-45 ²
Big kit for flushing head	797-5464-59 ¹ 797-5464-60 ²

1 = Non lubrication
2 = Lubrication

RECOMMENDED LUBRICANTS

Air tool oil, 1 liter	797-5870-90
Grease, 0.42 kg cartridge	797-5773-22

RG510

WATER CIRCULATION UNIT

GRINDING APPLICATIONS

Water circulation unit used to take care of cobalt particles in the coolant water, generated from grinding machines. This minimizes operators exposure of hazardous substances. Sandvik Water circulation unit is designed for workshop use and can be integrated with any variant of Sandvik grinding machine.

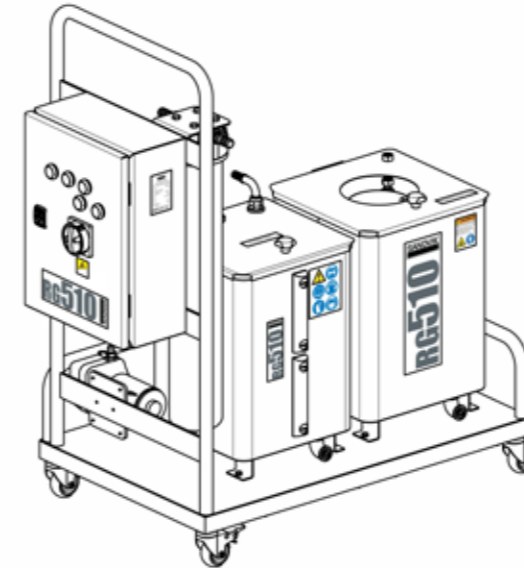

TECHNICAL DATA

Air supply pressure	Max 10 bar/min 6 bar
Air consumption	Max. 200 LPM
Air connection, air hose	6 mm (1/4")
Water connection, water hose	12 mm (1/2")
Flushing pump (to grinding machine)	1 LPM to 20 LPM Pr. 2.5 Bar, 24VDC
Filtering pump (to filter)	12.5 LPM, Pr. 2.5 Bar, 24VDC
Filter rating	5 µm, long PP
Filter dimension	Ø x L 2.5" x 20" (63.5 x 508 mm)
Filtered water tank capacity	30 Liters
Sedimentation tank capacity	34 Liters
Dimensions: H x W x D	1010 x 1012 x 525 mm
Weight (dry weight)	35 Kgs

PART. NO FOR MACHINES

Grinder 796-3700-00

VOLTAGE/PHASE ALT.

Voltage	Phases	Hz
220–240 V	1	50/60 Hz

RECOMMENDED SPARE PARTS

Filter	797-3703-03
--------	-------------

RG520

DUST EXHAUST UNIT

GRINDING APPLICATIONS

Dust exhaust unit used to collect cobalt dust generated from grinding machines. This minimizes operators exposure of hazardous substances. Sandvik Dust exhaust unit is designed for workshop use and can be integrated with any variant of Sandvik grinding machine



TECHNICAL DATA

Air flow	2000 m ³ /hour
Pressure	40 mm of water gauge (0.03 bar)
Motor rated power	1.1 KW
Noise Level	68 dBA
Exhaust unit dimensions: H x W x D	545 x 525 x 525 mm
Exhaust unit weight	45 kg
Exhaust unit and stand dimensions: H x W x D	2286 x 525 x 525 mm
Exhaust unit and stand weight	65 kg

PART. NO FOR MACHINES

Grinder 796-3600-XX*

*For two last digits, see table below, under "Code".

VOLTAGE/PHASE ALT.

Voltage	Phases	Hz	Code
380-420 V	3	50/60 Hz	52
220-240 V	3	50/60 Hz	59

RECOMMENDED SPARE PARTS

Filter 797-3601-08

GRINDING WHEELS

GRINDING WHEELS FOR RG100P, RG100H, RG120P AND RG120E

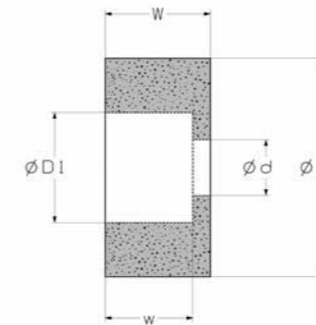

GRINDING WHEEL FOR RG100

D	W	d	D1	w	COMMENT	PART.NO
127	63	32	80	50	dry or wet grinding	797-1227-15
127	63	32	80	50	wet grinding	797-1227-10

GRINDING WHEEL FOR RG120

D	W	d	D1	w	Comment	part.no
150	83	63.5	100	64	wet grinding	797-1252-10

GRINDING WHEELS FOR SECOROC: JUNIOR AND SENIOR, ATLAS COPCO: TEROC 1500/1501

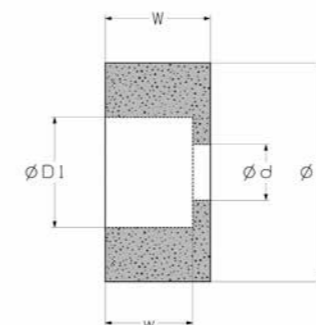

SECOROC: JUNIOR AND SENIOR, ATLAS COPCO: TEROC 1500/1501

D	W	d	D1	w	COMMENT	PART.NO
200	102	32	150	80	wet grinding	797-1250-10

GRINDING WHEELS

GRINDING WHEELS FOR RG300, RG320, RG340 AND RG360

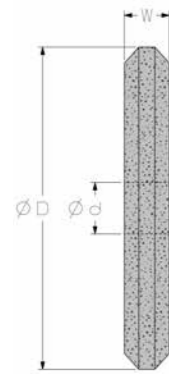

BIT INSERT ANGLE	BIT Ø, MM	WHEEL ANGLE	D	W	d	COMMENT	PART.NO
90°, Cross bits	33–35	132°	300	23	32	wet grinding	797-1190-23
90°, Cross bits	43–45	132°	300	29	32	wet grinding	797-1190-29
90°, Cross bits	48–51	132°	300	32	32	wet grinding	797-1190-32

GRINDING WHEELS FOR RG140

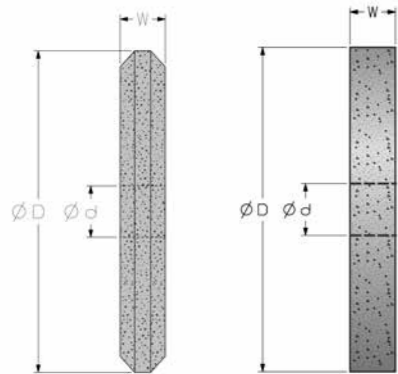

BIT INSERT ANGLE	BIT Ø, MM	WHEEL ANGLE	D	W	d	COMMENT	PART.NO
90°, Cross bits	33–39	132°	200	25	32	dry grinding	797-1101-25
90°, Cross bits	33–43	132°	200	28	32	dry grinding	797-1185-28
Straight wheel for gauge grinding			200	32	32	dry grinding	797-1101-32

GRINDING CUPS

GRINDING CUPS FOR RG400, RG410, RG420, RG440, RG460 AND RG470 GRINDERS

SANCUP SUPER (S)

Grinding cups for redressing spherical (and super-spherical) buttons. Shank Ø 9 mm.

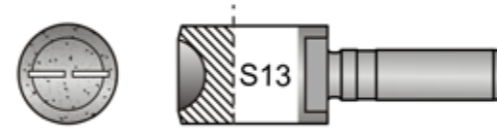

* = straight water flushing slots



** = three water flushing slots

FOR BUTTON SIZE	PART. NO
7 mm	797-5120-07*
8 mm	797-5120-08*
9 mm	797-5120-09*
10 mm	797-5120-10*
11 mm	797-5120-11*
12 mm	797-5120-12**
13 mm	797-5120-13**
14 mm	797-5120-14**
15 mm	797-5120-15**
16 mm	797-5120-16**
18 mm	797-5120-18**
19 mm	797-5120-19**
20 mm	797-5120-20**
22 mm	797-5120-22**

SANCUP SUPER (B)

Grinding cups for redressing semi ballistic buttons. Shank Ø 9 mm.

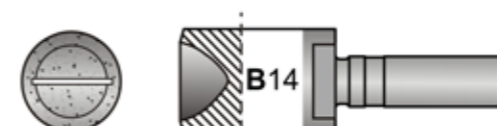

* = straight water flushing slots



** = three water flushing slots

FOR BUTTON SIZE	PART. NO
7 mm	797-5121-07*
8 mm	797-5121-08*
9 mm	797-5121-09*
10 mm	797-5121-10*
11 mm	797-5121-11**
12 mm	797-5121-12**
13 mm	797-5121-13**
14 mm	797-5121-14**
16 mm	797-5121-16**
18 mm	797-5121-18**
19 mm	797-5121-19**
22 mm	797-5121-22**

GRINDING ACCESSORIES

WHEEL DRESSER

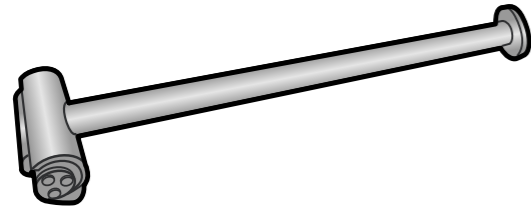

¹⁾ Included in a complete unit.

DESCRIPTION	PART. NO
Wheel dresser, complete	796-1858
Shaft (1 pcs) ¹⁾	796-1862
Bearing bushing (2 pcs) ¹⁾	796-1863
Screw (6 pcs) ¹⁾	796-1865
Cover (2 pcs) ¹⁾	796-1866
1 set of dresser rollers ¹⁾	796-1867

GRINDING TEMPLATES

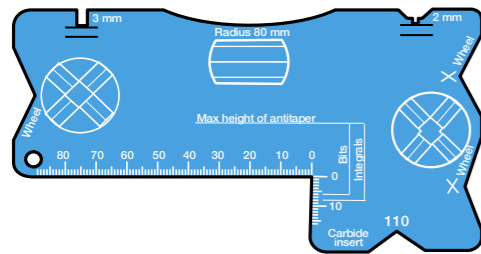

Grinding template for integrals steels / Grinding template for cross and X-bits with diameter up to 115 mm.

DESCRIPTION	PART. NO
Grinding template	795-1343

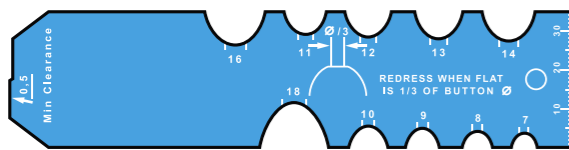

Grinding template for spherical buttons.

DESCRIPTION	PART. NO
Grinding template, spherical buttons	795-1397
Grinding template, semi ballistic buttons	795-1398

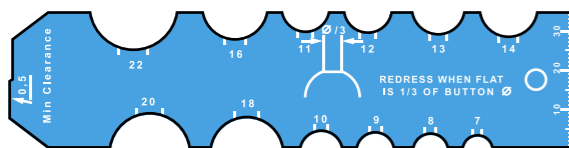

Grinding template for semi ballistic buttons.

NUMERICAL INDEX WITH WEIGHT TABLE

Item Code	Item Description	Weight (kg)
5770-5433M-B49	TAPERED BUTTON BIT 33MM 12 DEG	0,3
5770-5433M-B70	TAPERED BUTTON BIT 33MM 12 DEG	0,3
714-0434-65	INTEGRAL STEEL H22 34MM L=400MM	1,7
714-0635-65	INTEGRAL STEEL H22 35MM L=600MM	2,3
714-0641-65	INTEGRAL STEEL H22 41MM L=600MM	2,3
714-0833-65	INTEGRAL STEEL H22 33MM L=800MM	2,9
714-0834-65	INTEGRAL STEEL H22 34MM L=800MM	2,9
714-0840-65	INTEGRAL STEEL H22 40MM L=800MM	2,9
714-1232-65	INTEGRAL STEEL H22 32MM L=1200MM	4,1
714-1234-65	INTEGRAL STEEL H22 34MM L=1200MM	4,1
714-1240-65	INTEGRAL STEEL H22 40MM L=1200MM	4,1
714-1628-50	INTEGRAL STEEL H22 28MM L=1600MM	5,3
714-1633-65	INTEGRAL STEEL H22 33MM L=1600MM	5,3
714-1639-65	INTEGRAL STEEL H22 39MM L=1600MM	5,3
714-1833-65	INTEGRAL STEEL H22 33MM L=1800MM	6,0
714-1839-65	INTEGRAL STEEL H22 39MM L=1800MM	6,0
714-2033-65	INTEGRAL STEEL H22 33MM L=2000MM	6,5
714-2432-65	INTEGRAL STEEL H22 32MM L=2400MM	7,7
714-2438-65	INTEGRAL STEEL H22 38MM L=2400MM	7,7
714-3231	INTEGRAL STEEL H22 31MM L=3200MM	10,3
714-3237-65	INTEGRAL STEEL H22 37MM L=3200MM	10,3
714-4030	INTEGRAL STEEL H22 30MM L=4000MM	12,5
714-4036-65	INTEGRAL STEEL H22 36MM L=4000MM	12,5
714-4829	INTEGRAL STEEL H22 29MM L=4800MM	15,0
714-4835-65	INTEGRAL STEEL H22 35MM L=4800MM	15,0
714-5628-50	INTEGRAL STEEL H22 28MM L=5600MM	17,0
714-5634-65	INTEGRAL STEEL H22 34MM L=5600MM	17,0
714-6427-50	INTEGRAL STEEL H22 27MM L=6400MM	19,8
714-6433-65	INTEGRAL STEEL H22 33MM L=6400MM	19,8
714-7226-50	INTEGRAL STEEL H22 26MM L=7200MM	22,5
714-7232-65	INTEGRAL STEEL H22 32MM L=7200MM	22,5
714-8026-50	INTEGRAL STEEL H22 26MM L=8000MM	24,7
714-9625-5005	INTEGRAL STEEL H22 25MM L=9600MM	29,5
7304-3550-01	SHANK T38 COP1038HB/HL/1238 D45	5,4
7304-3590-03	SHANK T38 COP10/1238HD H200 D38 L4	4,1
7304-3593-01	SHANK T38 COP1038HL/1238 D38 L575	4,7
7304-3652-01	SHANK T38 COP1440/1638/1838/2238	3,8
7304-3655-01	SHANK T38 COP1550/1838 ME D52 L525	6,3
7304-3656-01	SHANK T38 COP1440/1638/1838/2238	4,4
7304-3663-01	T38 SHANK COP 1838MUX/HUX L730 D52	9,6
7304-3674-01	SHANK T38 COP3038 D45 L435	4,8
7304-3685-01	SHANK T38 COP MD20 D38 L470	4,4
7304-3690-02	SHANK T38 COP1850/1840/1240/1640	6,7
7304-4720-01	SHANK T38 HC80/90/105 D38 L440	3,8
7304-4725-01	SHANK T38 HC40/HC50 D38 L447	3,6
7304-4735-01	SHANK T38 HC110 D45 L420	4,7
7304-4762-01	SHANK T38 HC50 D38 L381	3,2
7304-4993-01	SHANK T38 HD125, HD150 D45 L495	5,5
7304-7426-01	SHANK T38 HD709 D45 L620	6,3
7304-7500-60	SHANK T38 PR123,URD475/550 D44L446	4,0
7304-7525-19	SHANK T38 YH65/70/75/80 D45 L495	5,5
7304-7531-01	SHANK T38 HL500S/510S/B/LH D38L460	4,1
7304-7535-02	SHANK T38 HL500/510 D38 L550	4,6
7304-7536-01	SHANK T38 HL500S/510S/B/LH D38 L500	4,3
7304-7543-60	SHANK T38 PR123 URD475/550 D44 L3	3,7

NUMERICAL INDEX WITH WEIGHT TABLE

Item Code	Item Description	Weight (kg)
7304-7544-01	SHANK T38 HC80R/120R D45 L670	7,3
7304-7554-01	SHANK T38 HL550/560/510T/S D45 L50	5,3
7304-7557-01	SHANK T38 HL500/510/510 D45 L550	5,6
7304-7576-01	SHANK T38 HL700/700/650 D45 L600	6,9
7304-7577-02	SHANK T38 HL700/S/LH/PE/650	8,4
7304-7585-01	SHANK T38 HLX5/T D45 L500	5,3
7304-7586-01	SHANK T38 HLX5/T D45 L575	5,7
7304-7656-01	SHANK T38 RD212 D38 L540	4,3
7304-7657-01	SHANK T38 RD315 D38 L555	4,8
7304-7664-01	SHANK T38 HLX5/T PE D45 L575	6,1
7304-7666-01	SHANK T38 RD520/525/535 D45 L600	6,0
7304-7669-01	SHANK T38 RD520/525 D45 L525	5,6
7304-7672-01	SHANK T38 RD308/314/315/414D38L410	3,5
7304-7673-01	SHANK T38 RD520/525PE D45 L745	7,9
7304-7685-01	SHANK T38 RD520/525/535 D45 L745	7,6
7304-7711-15	SHANK T38 RD900-PE D52 L600	8,6
7305-3593-01	SHANK T45 COP1038HL/1238 D45 L575	5,8
7305-3655-01	SHANK T45 COP1550/1838 ME D52 L525	6,5
7305-3663-01	SHANK T45 COP1838 MUX/HUX L730 D52	9,9
7305-3667-01	SHANK T45 COP3038 D45 L435	4,5
7305-3690-02	SHANK T45 COP1840 D52 L565	6,9
7305-3826-02	SHANK T45 COP1838 MEX/HEX D60 L730	10,3
7305-3891-02	SHANK T45 COP1840/2550/1640/2150EX	10,8
7305-6008-01	SHANK T45 HL1000S D52 L590	9,2
7305-6010-01	SHANK T45 HL1000 D52 L670	9,7
7305-7417-01	SHANK T45 HD712 D51 L788	9,5
7305-7525-19	SHANK T45 YH65/70/75/80 D45 L500	5,5
7305-7532-01	SHANK T45 HL600/600S D45 L600	6,4
7305-7546-19	SHANK T45 YH65/70/75/80RP D45 L700	8,0
7305-7557-01	SHANK T45 HL500/510/510 D45 L550	5,9
7305-7559-19	SHANK T45 YH80A D50.9 L495	6,1
7305-7576-01	SHANK T45 HL700/700/650 D45 L600	7,4
7305-7577-02	SHANK T45 HL650/700/710/800	8,6
7305-7586-01	SHANK T45 HLX5/T D45 L575	6,0
7305-7669-01	SHANK T45 RD520/525 D45 L525	5,7
7305-7711-15	SHANK T45 RD900/RD900PE D52 L600	9,0
7305-7711P-15	SHANK T45 RD900/RD900PE D52 L600	9,0
7305-7714-15	SHANK T45 RD900 TUBE D65 L670	13,1
7305-7717-15	SHANK T45 RD900-PE TUBE D65 L670	14,4
7305-7721-15	SHANK T45 RD900/RD900PE D52 L820	10,7
7305-7721P-15	SHANK T45 RD900/RD900PE D52 L820	10,7
7306-3689-01	SHANK T51 COP2160/2560 D60 L770	11,7
7306-3690-03	SHANK T51 COP1840/1850 D52 L565	7,2
7306-3699-01	SHANK T51 COP2160EX/2560EX D63L770	13,3
7306-3700-01	SHANK T51 COP2560EX+ D63 L770	13,4
7306-4885-02	SHANK T51 HPR2 D51 L916	13,7
7306-6010-02	SHANK T51 HL1000 D52 L670	10,1
7306-6014-02	SHANK T51 HL1000/1010 D60 L670	12,0
7306-6025-02	SHANK T51 HL1000/1500PE D65 L760	15,8
7306-7424-01	T51 SHANK HD715RP 8SPL D58 L885	15,6
7306-7528-02	SHANK T51 HC80R/120R/150R D51 L670	9,0
7306-7577-03	SHANK T51 HL700/S/LH/PE/650	8,9
7306-7711-15	SHANK T51 RD900/RD900PE D52 L600	9,1
7306-7711P-15	SHANK T51 RD900/RD900PE D52 L600	9,1
7306-7712-15	SHANK T51 RD900/RD900PE D52 L670	9,8

NUMERICAL INDEX WITH WEIGHT TABLE

Item Code	Item Description	Weight (kg)
7306-7715-15	SHANK T51 RD900 D65 L670	12,3
7306-7715P-15	SHANK T51M RD900-65 ROCKP D65 L670	12,5
7306-7716-15	SHANK T51 RD900-PE D65 L670	13,7
7306-7716P-15	SHANK T51 RD900-PE D65 L670 ROCKP	14,5
7306-7721-15	SHANK T51 RD900/RD900PE D52 L820	11,4
7306-7721P-15	SHANK T51 RD900/RD900PE D52 L820	11,4
7306-7728-15	SHANK T51 RD900 D70 L820	17,0
7307-7566-01	SHANK T35 HL550/560/510T/S D45 L46	4,9
7307-7586-01	SHANK T35 HLX5/T D45 L575	5,6
7307-7673-01	SHANK T35 RD520/525PE D45 L745	7,7
7314-3155	COUPLING SLEEVE T38	2,0
7314-3355	COUPLING SLEEVE T38	2,0
7314-3555	COUPLING T38/R32	2,3
7314-3652	COUPLING SLEEVE T38	1,6
7314-4455	COUPLING SLEEVE T38/R38	1,9
7314-4952	COUPLING SLEEVE T38/A330	1,7
7314-6258	COUPLING SLEEVE T45/T38	2,0
7314-6261	COUPLING SLEEVE T45/T38	2,4
7315-3663	COUPLING T45	1,7
7316-3671	COUPLING T51	3,1
7316-3676	COUPLING SLEEVE T51	4,6
7316-6271	COUPLING SLEEVE T51/T45	4,0
7324-4331C-30	EXTENSION ROD T38 R39 L=3050MM	24,4
7324-4337C-30	EXTENSION ROD T38 R39 L=3660MM	29,3
7324-4343C-30	EXTENSION ROD T38 R39 L=4265MM	34,3
7324-4709C-20	MF ROD T38 R39 L=915MM	8,0
7324-4712C-20	MF ROD T38 R39 L=1220MM	10,4
7324-4715C-20	MF ROD T38 R39 L=1525MM	12,8
7324-4718C-20	MF ROD T38 R39 L=1830MM	15,3
7324-4724C-20	MF ROD T38 R39 L=2435MM	20,1
7324-4731-70	MF ROD T38 R39 L=3050MM	25,0
7324-4731-85	MF ROD T38 L=3050MM	25,1
7324-4737-85	MF ROD T38 L=3660MM	29,9
7324-4743-85	MF ROD T38 L=4265MM	34,8
7324-4749-85	MF ROD T38 L=4875 MM	39,6
7324-6537-20	DRIFTER ROD T38 H35 R32 L=3700MM	29,3
7324-6543-20	DRIFTER ROD T38 H35 R32 L=4305MM	34,0
7324-6724-20	DRIFTER ROD T38 H35 A330 L=2475MM	18,8
7324-6731-20	DRIFTER ROD T38 H35 A330 L=3090MM	24,0
7324-6737-20	DRIFTER ROD T38 H35 A330 L=3700MM	29,0
7324-6743-20	DRIFTER ROD T38 H35 A330 L=4305MM	33,6
7324-6749-20	DRIFTER ROD T38 H35 A330 L=4915MM	39,2
7324-6755-20	DRIFTER ROD T38 H35 A330 L=5525MM	43,0
7324-6843-20	DRIFTER ROD T38 R39 A360 L=4305	34,3
7324-6849-20	DRIFTER ROD T38 R39 A360 L=4915	38,9
7324-6855-20	DRIFTER ROD T38 R39 A360 L=5525	49,0
7324-6861-20	DRIFTER ROD T38 R39 A360 L=6135	49,1
7324-7049-20	DRIFTER ROD T38 R39 A330 L=4915M	40,9
7324-7055-20	DRIFTER ROD T38 R39 A330 L=5525MM	46,1
7324-7061-20	DRIFTER ROD T38 R39 A330 L=6135	51,5
7324-7064-20	DRIFTER ROD T38 R39 A330 L=6440M	53,8
7324-7243-20	DRIFTER ROD T38 R39 R35 L=4305MM	34,2
7324-7249-20	DRIFTER ROD T38 R39 R35 L=4915MM	39,9
7324-7255-20	DRIFTER ROD T38 R39 R35 L=5525MM	44,0
7324-7261-20	DRIFTER ROD T38 R39 R35 L=6135MM	48,9

NUMERICAL INDEX WITH WEIGHT TABLE

Item Code	Item Description	Weight (kg)
7324-7455-20	DRIFTER ROD T38 H35 A360 L=5525	44,0
7324-8149-20	DRIFTER ROD T38 R39 A360 L=4915	39,2
7324-8155-20	DRIFTER ROD T38 R39 A360 L=5525	44,1
7324-8161-20	DRIFTER ROD T38 R39 A360 L=6135	49,1
7324-8543-20	DRIFTER ROD T38 H35 R35 L=4305MM	33,7
7324-8549-20	DRIFTER ROD T38 H35 R35 L=4915MM	38,5
7324-8555-20	DRIFTER ROD T38 H35 R35 L=5525MM	43,1
7324-8631-20	DRIFTER ROD T38 H32 R32 L=3090MM	19,6
7324-8637-20	DRIFTER ROD T38 H32 R32 L=3700MM	23,5
7324-8643-20	DRIFTER ROD T38 H32 R32 L=4305MM	27,3
7324-9624-20	DRIFTER ROD T38 H35 R32 L=2475MM	19,0
7324-9631-20	DRIFTER ROD T38 H35 R32 L=3090MM	24,0
7324-9637-20	DRIFTER ROD T38 H35 R32 L=3700MM	28,7
7324-9643-20	DRIFTER ROD T38 H35 R32 L=4305MM	34,0
7324-9649-20	DRIFTER ROD T38 H35 R32 L=4915MM	38,2
7324-9655-20	DRIFTER ROD T38 H35 R32 L=5525MM	43,0
7324-9661-20	DRIFTER ROD T38 H35 R32 L=6135MM	47,8
7324-9664-20	DRIFTER ROD T38 H35 R32 L=6440MM	50,0
7325-0637C-20	MF ROD T45 R52 L=3660MM	52,0
7325-0643C-20	MF ROD T45 R52 L=4265MM	60,5
7325-7331C-30	EXTENSION ROD T45 R46 L=3050MM	33,2
7325-7337C-30	EXTENSION ROD T45 R46 L=3660MM	43,0
7325-7343C-30	EXTENSION ROD T45 R46 L=4265MM	46,7
7325-7712C-20	MF ROD T45 R46 L=1220MM	15,1
7325-7715C-20	MF ROD T45 R46 L=1525MM	18,6
7325-7718C-20	MF ROD T45 R46 L=1830MM	22,1
7325-7731-85	MF ROD T45 R46 MTL L=3050MM	36,3
7325-7737-70	MF ROD T45 R46 L=3660MM	43,2
7325-7737-85	MF ROD T45 R46 MTL L=3660MM	43,4
7325-7743-85	MF ROD T45 R46 MTL L=4265MM	50,4
7325-7749-85	MF ROD T45 R46 MTL L=4875MM	57,4
7325-7761-85	MF ROD T45 R46 MTL L=6095MM	71,5
7326-5308C-20	T51 EXTENSION ROD WITH WRENCH FL	10,0
7326-5337C-30	EXTENSION ROD T51 R52 L=3660MM	50,0
7326-5343C-30	EXTENSION ROD T51 R52 L=4265MM	58,0
7326-5361C-30	EXTENSION ROD T51 R52 L=6095MM	83,9
7326-5512C-20	MF ROD T51 R52 L=1220MM	18,3
7326-5515C-20	MF ROD T51 R52 L=1525MM	22,5
7326-5518C-20	MF ROD T51 R52 L=1830MM	27,0
7326-5537-70	MF ROD T51 R52 L=3660MM	52,5
7326-5537-85	MF ROD T51 R52 MTL L=3660MM	52,0
7326-5543-85	MF ROD T51 R52 MTL L=4265MM	60,7
7326-5549-85	MF ROD T51 R52 MTL L=4875MM	69,2
7326-5555-85	MF ROD T51 R52 MTL L=5485MM	77,7
7326-5561-85	MF ROD T51 R52 MTL L=6095MM	87,0
7327-4715-20	MF ROD T35-R39-T35 L1525 MM	12,2
7327-4718-20	MF ROD T35 R39 L=1830MM	14,6
7327-4737-20	MF ROD T35 R39 L=3660MM	29,2
7327-4749-20	MF ROD T35 R39 L=4875MM	40,1
7328-3720-01	SHANK ST58 COP4050 MUX D90 L835	26,5
7328-6020-01	SHANK ST58 HL1500/LH/S D80 L635	17,3
7328-6035-01	SHANK ST58 HL1000/1500/S/PE	22,4
7328-7718-15	SHANK ST58 RD900 D70 L670	14,3
7329-6009-02	SHANK ST68 HL1000/S D80 L640	18,0
7329-6020-05	SHANK ST68 HL1500/S/LH D80 L635	17,9

NUMERICAL INDEX WITH WEIGHT TABLE

Item Code	Item Description	Weight (kg)
7329-6035-05	SHANK ST68 HL1000/1500S D90 L635	22,4
7334-3301	BIT ADAPTER T38F/R32M	2,6
7334-4405-64	GUIDE ADAPTER T38 64 MM	2,8
7334-4405-76	GUIDE ADAPTER T38 76 MM	3,3
7334-5401	BIT ADAPTER T38F/T45M	3,4
7335-4401	BIT ADAPTER T45F/T38M	2,9
7335-5405-76	GUIDE ADAPTER T45 76 MM	4,0
7335-5405-89	GUIDE ADAPTER T45 89 MM	4,4
7335-6401	BIT ADAPTER T45F/T51M	3,7
7336-5401	BIT ADAPTER T51F/T45M	3,8
7336-6405-102	GUIDE ADAPTER T51 102MM	6,3
7336-6405-115	GUIDE ADAPTER T51 115MM	7,4
7336-6405-89	GUIDE ADAPTER T51 89MM	5,4
7337-4401	BIT ADAPTER T35F/T38M	1,9
7338-6801	BIT ADAPTER ST58F/ST68M	7,0
7340-6040-15	SHANK LT90 RD1840C D80 L850	26,7
7358-7716-15	SHANK ST58 RD900-PE D65 L670	14,2
7378-7615-26	DRILL TUBE ST58 L=1525MM	33,2
7378-7618-26	DRILL TUBE ST58 L=1830MM	39,7
7379-8715-26	DRILL TUBE ST68 L=1525MM	39,0
7379-8718-26	DRILL TUBE ST68 L=1830MM	46,2
7382-1543-85	MF-TUBE ROD LT90 4265MM	109,5
7514-1654A-R48	BUTTON BIT T38 54MM RT300	1,0
7514-1657A-S48	BUTTON BIT T38 57MM RT300	1,2
7514-1664-R48	BUTTON BIT T38 64MM RT300	1,5
7514-1664-S48	BUTTON BIT T38 64MM	1,5
7514-1870-S48	BUTTON BIT T38 70MM	1,9
7514-1876-R48	BUTTON BIT T38 76MM	2,1
7514-1876-S48	BUTTON BIT T38 76MM RT300	2,1
7514-1889-S48	BUTTON BIT T38 89MM RT300	2,9
7514-2602-S48	BUTTON BIT T38 102MM	4,0
7514-4660A-R48	RETRAC BIT T38 60MM RT300	1,8
7514-4664-R48	RETRAC BIT T38 64MM RT300	1,9
7514-4664-R70	RETRAC BIT T38 64 MM SH70	1,9
7514-4664-S48	RETRAC BIT T38 64MM RT300	2,0
7514-4664-S65	BIT RETRAC T38 64MM DP65	1,9
7514-4670-R70	RETRAC BIT T38 70MM SH70	2,5
7514-4864A-R70	RETRAC BIT T38 64MM SH70	2,1
7514-4864-R48	RETRAC BIT T38 64MM RT300	1,9
7514-4870-S48	RETRAC BIT T38 70MM RT300	2,7
7514-4876-R48	RETRAC BIT T38 76MM RT300	3,0
7514-4876-S48	RETRAC BIT T38 76MM RT300	2,9
7514-4876-S65	RETRAC BIT T38 76MM DP65	3,0
7514-5564A-C60	SOFT ROCK BIT T38 64MM	1,4
7514-5576A-C60	SOFT ROCK BIT T38 76MM	2,1
7514-5627-S48	REAMING BIT T38 127MM	5,1
7514-5652-S48	REAMING BIT T38 152MM	7,6
7514-7576A-C60	BUTTON BIT T38 76MM RETRAC DC	3,5
7514-7864A-S48	RETRAC BUTTON BIT T38 64MM	2,0
7514-7876A-S48	RETRAC BUTTON BIT T38 76MM	2,9
7514-7889-S48	RETRAC BIT T38 89MM	4,1
7514-7964-R48	BUTTON BIT T38 64MM DC	1,7
7514-7976-R48	BUTTON BIT T38 76MM DC	3,0
7514-7976-S48	BUTTON BIT T38 76MM DC	3,0
7514-8264-R48	GUIDE BIT T38 64MM RT300	2,1

NUMERICAL INDEX WITH WEIGHT TABLE

Item Code	Item Description	Weight (kg)
7515-1870-S48	BUTTON BIT T45 70MM	2,1
7515-1876-R48	BUTTON BIT T45 76MM	2,5
7515-1876-S48	BUTTON BIT T45 76MM RT300	2,3
7515-1889-R48	BUTTON BIT T45 89MM	3,1
7515-1889-S48	BUTTON BIT T45 89MM RT300	3,2
7515-1902-R48	BUTTON BIT T45 102MM RT300	4,0
7515-1902-S48	BUTTON BIT T45 102MM RT300	3,8
7515-2676A-S48	BUTTON BIT T45 76MM	2,4
7515-2689A-S48	BUTTON BIT T45 89MM	3,1
7515-4866-R48	RETRAC BIT T45 66MM RT300	2,0
7515-4870-R48	RETRAC BIT T45 70MM RT300	2,6
7515-4876-R70	RETRAC BIT T45 76MM SH70	2,9
7515-4876-S48	BUTTON BITRETRAC BIT T45 76MM	2,8
7515-4876-S65	RETRAC BIT T45 76MM	2,8
7515-4876-S70	RETRAC BIT T45 76MM S70	2,8
7515-4876-S81	RETRAC BIT T45 76MM S81	2,8
7515-4883-R48	RETRAC BIT T45 83MM RT300	3,9
7515-4889-R48	RETRAC BIT T45 89MM RT300	4,5
7515-4889-R70	RETRAC BIT T45 89MM R70	4,3
7515-4889-S48	RETRAC BIT T45 89MM RT300	4,2
7515-4889-S70	RETRAC BIT T45 89MM SH70	4,3
7515-4902-R48	RETRAC BIT T45 102MM RT300	6,4
7515-4902-S48	RETRAC BIT T45 102MM RT300	6,0
7515-5576A-C60	SOFT ROCK BIT T45 76 MM	2,2
7515-5589A-C60	SOFT ROCK BIT T45 89 MM	3,1
7515-5627-S48	REAMING BIT T45 127MM	5,5
7515-5652-S48	REAMING BIT T45 152MM	9,3
7515-7576A-C60	BUTTON BIT T45 76MM RETRAC DC	3,0
7515-7876A-S48	RETRAC BUTTON BIT T45 76MM	2,9
7515-7889A-S48	RETRAC BUTTON BIT T45 89MM	4,6
7515-7902-S48	BUTTON BIT T45 102MM RETRAC DC	5,6
7515-7976-R48	BUTTON BIT T45 76MM DC	2,9
7515-7976-S48	BUTTON BIT T45 76MM DC	2,8
7515-7989-R48	BUTTON BIT T45 89MM RETRAC	4,2
7515-7989-S48	BUTTON BIT T45 89MM DC	4,2
7515-8276-R48	GUIDE BIT T45 76MM RT300	3,2
7516-1889-R48	BUTTON BIT T51 89MM RT300	3,6
7516-1889-S48	BUTTON BIT T51 89MM RT300	3,6
7516-1902-R48	BUTTON BIT T51 102MM RT300	4,5
7516-1902-S48	BUTTON BIT T51 102MM RT300	4,5
7516-1915-S48	BUTTON BIT T51 115MM RT300	6,1
7516-1927-S48	BUTTON BIT T51 127MM RT300	6,8
7516-2689A-S48	BUTTON BIT T51 89MM	3,6
7516-4883-R70	RETRAC BIT T51 83MM SH70	3,7
7516-4883-S48	RETRAC BIT T51 83MM RT300	3,7
7516-4889-R70	RETRAC BIT T51 89MM SH70	3,9
7516-4889-S48	RETRAC BIT T51 89MM RT300	4,1
7516-4889-S70	RETRAC BIT T51 89MM SH70	4,1
7516-4889-S81	RETRAC BIT T51 89MM GC81	4,1
7516-4902-R48	RETRAC BIT T51 102MM RT300	6,2
7516-4902-S48	RETRAC BIT T51 102MM RT300	6,3
7516-4902-S65	RETRAC BIT T51 102MM	6,3
7516-4902-S70	RETRAC BIT 102MM SH70	6,1
7516-4915-R48	RETRAC BIT T51 115MM RT300	8,0
7516-4915-S48	RETRAC BIT T51 115MM RT300	7,8

NUMERICAL INDEX WITH WEIGHT TABLE

Item Code	Item Description	Weight (kg)
7516-4915-S70	RETRAC BIT T51 115MM SH70	7,9
7516-4927-S48	RETRAC BIT T51 127MM RT300	10,6
7516-5515A-C60	SOFT ROCK BIT T51 115 MM	6,0
7516-5589A-C60	SOFT ROCK BIT T51 89 MM	3,6
7516-5652-S48	REAMING BIT T51 152MM	8,8
7516-7002-S70	RETRAC BIT T51 102 MM	6,5
7516-7089-S70	RETRAC BIT T51 89 MM	4,4
7516-7502A-C60	BUTTON BIT T51 102MM RETRAC DC	6,1
7516-7589A-C60	BUTTON BIT T51 89MM RETRAC DC	4,3
7516-7889A-S48	RETRAC BUTTON BIT T51 89MM	4,3
7516-7902-R48	RETRAC BIT T51 102MM DC	5,4
7516-7902-S48	RETRAC BIT T51 102MM DC	5,4
7516-7915-S48	BUTTON BIT T51 115MM DC RETRAC	7,7
7516-7976-R48	BUTTON BIT T51 76MM RETRAC DC	2,8
7516-7989-R48	BUTTON BIT T51 89MM RETRAC DC	4,0
7516-7989-S48	BUTTON BIT T51 89MM RETRAC DC	4,0
7517-1654A-S48	BUTTON BIT T35 54MM RT300	1,1
7517-4654A-R48	RETRAC BIT T35 54MM	1,4
7517-4657A-R48	RETRAC BIT T35 57MM	1,5
7517-4664A-R48	RETRAC BIT T35 64 MM RT300	2,1
7525-4876-S48	RETRAC TUBE BIT T45 76 MM	3,1
7525-8476-R65	TUBE BIT T45 76MM XDC	3,4
7525-8489-R65	TUBE BIT T45 89MM XDC	3,8
7528-5604-S81	REAMING BIT ST58 204MM GC81	23,9
7528-5627-S81	REAMING BIT ST58 127MM GC81	7,5
7528-5652-S81	REAMING BIT ST58 152MM GC81	9,3
7528-5654A-S65	REAMING BIT ST58 254 MM	29,0
7528-6589-S70	TUBE BIT ST58 89MM SH70	3,5
7528-6989-S65	ST58 BUTTON BIT TUBE HEAVY DUTY	4,5
7528-7302-R70	TUBE BIT ST58 102MM SH70	6,7
7528-7315-R65	GUIDE BIT ST58 115MM	9,2
7528-7389-R65	TUBE BIT ST58 89MM XDC GUIDE	4,6
7528-7389-R70	RETRAC TUBE BIT ST58 89MM SH70	4,6
7528-8489-R65	TUBE BIT ST58 89MM XDC	4,1
7528-8489-R70	TUBE BIT ST58 89MM SH70	4,1
7528-8589-S70	TUBE BIT ST58 89MM RETRAC HD	4,2
7528-8589-S81	TUBE BIT ST58 89MM GC81	4,6
7528-8989-S65	TUBE BIT ST58 89MM RETRAC	4,6
7529-5604-S81	REAMING BIT ST68 204MM GC81	24,5
7529-5652-S81	REAMING BIT ST68 152MM GC81	11,9
7529-5654-S65	REAMING BIT ST68 254 MM	45,0
7529-6202-F70	AUTOBIT ST68 102 MM	5,0
7529-6302-F70	AUTOBIT RETRAC 102MM SH70	5,8
7529-6652-S48	COLLARING BIT ST68 152MM	9,0
7529-6902-S65	TUBE BIT ST68 102MM	5,1
7529-7302-R65	TUBE BIT ST68 102MM XDC GUIDE	5,7
7529-7302-R70	RETRAC TUBE BIT ST68 102MM SH70	5,6
7529-7315-R65	TUBE BIT ST68 115MM XDC GUIDE	8,2
7529-8402-R65	TUBE BIT ST68 102MM XDC	4,1
7529-8402-R70	TUBE BIT ST68 102MM SH70	5,1
7529-8415-R70	TUBE BIT ST68 115MM SH70	5,6
7529-8902-S65	TUBE BIT ST68 102MM RETRAC	5,7
7529-8902-S81	TUBE BIT ST68 102MM RETRAC GC81	5,7
7532-4940-S48	RETRAC BIT LT90 140MM XT48	12,3
7532-4965-S48	RETRAC BIT LT90 165MM XT48	22,0

NUMERICAL INDEX WITH WEIGHT TABLE

Item Code	Item Description	Weight (kg)
7532-4965-S70	RETRAC BIT LT90 165MM SH70	22,0
7532-4972-R48	RETRAC BIT LT90 172MM XT48	25,6
7539-1952-S70	BUTTON BIT CT67 152MM SH70	12,3
7539-4927-S70	RETRAC BIT CT67 127MM SH70	12,5
7568-1651A-S70	BUTTON BIT A360 51MM	1,0
7568-4864A-R48	RETRAC BIT 64MM A360	2,1
7568-5148A-S70	BUTTON BIT A360 48MM	0,9
7568-5348A-S70	BUTTON BIT A360 48MM	0,9
7568-5602P-S48	REAMING BIT A360 102MM	2,9
7568-5627P-S48	REAMING BIT A360 127MM	4,3
7568-6048-F49	SPEEDY BIT A360 48MM	0,9
7568-6051-F49	SPEEDY BIT A360 51MM	0,9
7600-3682-01	SHANK GT60 COP3060MEX D60 L840	17,3
7600-3699-01	SHANK GT60 COP2560EX L770 D63	14,4
7600-3712-01	SHANK GT60 COP4050ME D70 L700	14,6
7600-6014-02	SHANK GT60 HL1000/1010 D60 L670	13,1
7600-6022-03	SHANK GT60 HL1500 D60 L760	14,6
7600-6025-02	SHANK GT60 HL1000/1500PE D65 L760	16,7
7600-6025-05	SHANK GT60 HL1000/1500PE/1560HF D6	16,7
7600-6025-85	SHANK GT60 HL1000/1500/RD1635FC PE	16,9
7600-6025P-15	SHANK GT60 HL1000/HL1500/RD1635FC	17,0
7600-6030-05	SHANK GT60 HL1500 D80 L760	21,0
7600-6030-15	GT60 SHANK RD1635CF-80 D80 L760	21,0
7600-6030-85	SHANK GT60 HL1560/RD1635FC D80 L76	21,0
7600-6030P-15	SHANK GT60 HL1560/RD1635FC ROCKP D	21,0
7600-6032-05	SHANK GT60 HL1500/1560T D90 L760	25,4
7600-7530-02	SHANK GT60 HC200A D60 L840	17,0
7600-7715-15	SHANK GT60 RD900 D65 L670	13,1
7600-7715P-15	SHANK GT60 RD900-65 ROCKP D65 L670	13,1
7600-7716-15	SHANK GT60 RD900-PE D65 L670	14,5
7600-7716P-15	SHANK GT60 PE RD900 D65 L670 ROCKP	14,6
7600-7718-15	SHANK GT60 RD900 D70 L670	14,7
7600-7718P-15	SHANK GT60 RD900 D70 L670 ROCKP	14,7
7600-7728-15	SHANK GT60 RD900 D70 L820	17,7
7610-1137-85	MF ROD GT60 R60 MTL L=3660MM	73,0
7610-1143-85	MF ROD GT60 R60 MTL L=4265MM	86,0
7610-1155-85	MF ROD GT60 R60 MTL L=5485MM	108,3
7610-1161-85	MF ROD GT60 R60 MTL L=6095MM	120,0
7610-1243-85	MF ROD GT60+ R64 MTL L=4265MM	100,0
7610-1437-85	GT60 MF-ROD 3660MM 82MM COUPL DIA	72,7
7610-1443-85	MF ROD GT60 R60 MTL L=4265MM	84,0
7620-1892-S48	BUTTON BIT GT60 92MM RT300	5,0
7620-1902-S48	BUTTON BIT GT60 102MM RT300	6,1
7620-1915-S48	BUTTON BIT GT60 115MM RT300	7,5
7620-1927-S48	BUTTON BIT GT60 127MM RT300	9,0
7620-1940-S48	BUTTON BIT GT60 140MM	12,1
7620-1940-S70	BUTTON BIT GT60 140MM SH70	13,1
7620-1952-S48	BUTTON BIT GT60 152MM RT300	13,3
7620-4902-R48	RETRAC BIT GT60 102MM RT300	7,2
7620-4902-S48	RETRAC BIT GT60 102MM RT300	7,2
7620-4902-S70	RETRAC BIT GT60 102MM SH70	7,5
7620-4915-R48	RETRAC BIT GT60 115MM RT300	9,7
7620-4915-S48	RETRAC BIT GT60 115MM RT300	9,6
7620-4915-S65	RETRAC BIT GT60 115MM RT300	9,6
7620-4915-S70	RETRAC BIT GT60 115MM SH70	9,9

NUMERICAL INDEX WITH WEIGHT TABLE

Item Code	Item Description	Weight (kg)
7620-4927-R48	RETRAC BIT GT60 127MM RT300	12,5
7620-4927-S48	RETRAC BIT GT60 127MM RT300	12,8
7620-4927-S55	RETRAC BIT GT60 127MM RT300	12,8
7620-4927-S70	RETRAC BIT GT60 127MM SH70	12,8
7620-4927-S81	RETRAC BIT GT60 127 MM GC81	12,8
7620-4940-S48	RETRAC BIT GT60 140MM	16,0
7620-4940-S70	RETRAC BIT GT60 140MM SH70	16,0
7620-4952-S48	RETRAC BIT GT60 152MM RT300	18,9
7620-7002-S70	RETRAC BIT GT60 102MM SH70	7,3
7620-7902-S48	RETRAC BIT GT60 102MM RT300 DC	7,0
7620-7915-S48	RETRAC BIT GT60 115MM RT300 DC	9,1
7620-7927-S48	RETRAC BIT GT60 127 MM RT300 DC	12,5
7620-7940-S48	RETRAC BIT GT60 140MM RT300 DC	15,8
7620-8115-S55	RETRAC BIT GT60 115MM	9,5
7620-8115-S81	RETRAC BIT GT60 115MM GC81	9,5
7620-8702-R48	RETRAC BIT GT60 102MM RT300	7,5
7620-8792-R48	RETRAC BIT GT60 92MM RT300	6,0
7620-8792-S48	RETRAC BIT GT60 92MM RT300	6,1
7620-8796-R48	RETRAC BIT GT60 96MM RT300	6,6
7630-6005-115	GUIDE ADAPTER GT60 115MM	11,3
7630-6005-127	GUIDE ADAPTER GT60 127MM	14,4
7630-6005-140	GUIDE ADAPTER GT60 140MM	17,6
7630-6005-152	GUIDE ADAPTER GT60 152MM	18,5
7640-7653-80	PILOT TUBE GT60+ 76MM L=5335M	115,7
7640-8716-80	PILOT ROD GT60 87MM L=1600	44,1
7640-8743-80	PILOT TUBE GT60+ 87MM L=4265M	107,2
7660-8743-80	DRILL TUBE GT60+ 87MM L=4265M	104,5
7721-4802-S48	REAMING BIT 12DEG X 51.5MM 102MM	2,1
7721-4827-S48	REAMING BIT 12 DEG X51.5MM 127MM	3,5
7721-4889-S48	REAMING BIT 12 DEG X 51.5MM 89MM	1,5
7722-4864-S48	REAMING BIT 6 DEG X 33.5MM D64	0,9
7722-4876-S48	REAMING BIT 6 DEG X 33.5MM 76MM	1,3
7722-4889-S48	REAMING BIT 6 DEG X 33.5MM D89	1,7
7723-4802-S48	REAMING BIT 12 DEG X 63.1MM 102M	3,6
7723-4827-S48	REAMING BIT 12 DEG X 63.1MM 127M	5,2
7731-1038-42	CROSS BIT R22 38MM	0,4
7732-1651-R48	BUTTON BIT R25 51 MM	0,6
7732-4433C-R48	BUTTON BIT R25 33MM RT300	0,4
7732-4433C-S48	BUTTON BIT R25 33MM	0,3
7732-4435-S48	BUTTON BIT R25 35MM RT300	0,4
7732-4435-S70	DRIFTER BIT R25 35MM	0,4
7732-4435-S80	DRIFTER BIT R25 35MM GC80	0,4
7732-4435-S81	BUTTON BIT R25 35MM GC81	0,4
7732-4437C-S48	BUTTON BIT R25 37MM RT300	0,5
7732-5235-R48	BUTTON BIT R25 35MM RT300	0,4
7732-5238-R48	BUTTON BIT R25 38MM RT300	0,5
7732-5238-S48	BUTTON BIT R25 38MM RT300	0,5
7732-5241-S48	BUTTON BIT R25 41MM RT300	0,5
7732-5348A-S48	BUTTON BIT R25 48MM RT300	0,7
7732-6045-F49	BUTTON BIT R25 45 MM	0,6
7733-1345A-42	CROSS BIT R32 45MM	0,8
7733-1651A-R48	BUTTON BIT R32 51MM RT300	0,9
7733-1651A-S48	BUTTON BIT R32 51MM RT300	0,9
7733-1657A-S48	BUTTON BIT R32 57MM RT300	1,2
7733-1664-S48	BUTTON BIT R32 64MM RT300	1,6

NUMERICAL INDEX WITH WEIGHT TABLE

Item Code	Item Description	Weight (kg)
7733-1876-S48	BUTTON BIT R32 76MM RT300	1,8
7733-4651-R48	RETRAC BIT R32 51MM	1,2
7733-4651-S48	RETRAC BIT R32 51MM RT300	1,2
7733-4664-S48	RETRAC BIT R32 64MM RT300	2,3
7733-4864-S48	RETRAC BIT R32 64MM RT300	2,4
7733-5241-S48	BUTTON BIT R32 41MM RT300	0,7
7733-5243A-S48	BUTTON BIT R32 43MM RT300	0,7
7733-5243A-S70	DRIFTER BIT R32 43MM	0,7
7733-5245A-S48	BUTTON BIT R32 45MM RT300	0,8
7733-5248A-S48	BUTTON BIT R32 48MM RT300	0,9
7733-5251A-S48	BUTTON BIT R32 51MM RT300	0,9
7733-5343A-R48	BUTTON BIT R32 43MM RT300	0,7
7733-5345A-R48	BUTTON BIT R32 45MM RT300	0,8
7733-5345A-S48	BUTTON BIT R32 45MM RT300	0,8
7733-5345A-S70	DRIFTER BIT R32 45MM	0,8
7733-5348A-R48	BUTTON BIT R32 48MM RT300	0,9
7733-5348A-S48	BUTTON BIT R32 48MM RT300	0,9
7733-5443B-R48	BUTTON BIT R32 43MM RT300	0,7
7733-5445B-R48	BUTTON BIT R32 45MM RT300	0,8
7733-5557A-C60	SOFT ROCK BIT R32 57 MM	1,1
7733-5602P-S48	REAMING BIT R32 102MM	3,0
7733-5627P-S48	REAMING BIT R32 127MM	4,5
7733-5689-S45	REAMING BIT R32 89MM	2,8
7733-6043-F49	SPEEDY BIT 43 MM R32	0,7
7733-6045-F49	SPEEDY BIT R32 45MM	0,8
7733-6048-F49	SPEEDY BIT R32 48MM	0,9
7733-6051-F49	SPEEDY BIT R32 51MM	1,0
7737-4433-R48	BUTTON BIT R23 33MM RT300	0,3
7737-5235-R48	BUTTON BIT R23 35MM RT300	0,4
7737-5238A-R48	BUTTON BIT R23 38MM RT300	0,4
7737-5241-R48	BUTTON BIT R23 41MM RT300	0,5
7737-5345-R48	BUTTON BIT R23 45MM RT300	0,7
7738-1651A-R48	BUTTON BIT R35 51MM RT300	1,0
7738-1651A-S48	BUTTON BIT R35 51MM RT300	1,0
7738-4654A-R48	RETRAC BIT R35 54MM	1,4
7738-5148A-S80	BUTTON BIT R35 48MM TC	0,9
7738-5348A-R48	BUTTON BIT R35 48MM RT300	1,0
7738-5348A-S48	BUTTON BIT R35 48MM RT300	1,0
7738-5602P-S48	REAMING BIT R35 102MM	2,9
7739-5237-S48	BUTTON BIT R28 37MM RT300	0,5
7739-5238-R48	BUTTON BIT R28 38MM RT300	0,6
7739-5238-S48	BUTTON BIT R28 38MM RT300	0,6
7739-5241-S48	BUTTON BIT R28 41MM RT300	0,6
7739-5243-S48	BUTTON BIT R28 43MM RT300	0,7
7739-5345-R48	BUTTON BIT R28 45MM RT300	0,7
7767-1345A-42	CROSS BIT A330 45MM	0,8
7767-1651A-R48	BUTTON BIT A330 51 MM	1,0
7767-1651A-S48	BUTTON BIT A330 51 MM	1,0
7767-1664-S48	BUTTON BIT A330 64MM	1,6
7767-1876-S48	BUTTON BIT A330 76MM	1,7
7767-4651A-S48	RETRAC BIT A330 51 MM	1,1
7767-5143A-S80	BUTTON BIT A330 43MM TC	0,7
7767-5143A-S81	BUTTON BIT A330 43MM TC GC81	0,7
7767-5145A-S70	DRIFTER BIT A330 45MM	0,8
7767-5145A-S80	BUTTON BIT A330 45MM TC	0,8

NUMERICAL INDEX WITH WEIGHT TABLE

Item Code	Item Description	Weight (kg)
7767-5145A-S81	BUTTON BIT A330 45MM TC GC81	0,8
7767-5148A-S80	BUTTON BIT A330 48MM TC	0,9
7767-5148A-S81	BUTTON BIT A330 48MM TC GC81	0,9
7767-5243A-S48	BUTTON BIT A330 43 MM	0,7
7767-5243A-S70	DRIFTER BIT A330 43MM	0,7
7767-5245A-S48	BUTTON BIT A330 45 MM	0,8
7767-5248A-S48	BUTTON BIT A330 48 MM	0,9
7767-5343A-R48	BUTTON BIT A330 43 MM	0,7
7767-5345A-R48	BUTTON BIT A330 45MM RT300	0,8
7767-5345A-S48	BUTTON BIT A330 45 MM	0,8
7767-5345A-S70	DRIFTER BIT A330 45MM	0,8
7767-5345A-S81	BUTTON BIT A330 45MM GC81	0,8
7767-5348A-R48	BUTTON BIT A330 48 MM	0,9
7767-5348A-S48	BUTTON BIT A330 48 MM	0,9
7767-5443A-S48	BUTTON BIT A330 43 MM	0,7
7767-5443B-R48	BUTTON BIT A330 43 MM	0,7
7767-5445B-R48	BUTTON BIT A330 45 MM	0,8
7767-5602P-S48	REAMING BIT A330 102MM	3,0
7767-5627P-S48	REAMING BIT A330 127 MM	4,4
7767-6043-F49	SPEEDY BIT A330 43MM	0,7
7767-6045-F49	SPEEDY BIT A330 45MM	0,8
7767-6048-F49	SPEEDY BIT A330 48MM	0,8
7767-6051-F49	SPEEDY BIT A330 51MM	0,9
7770-4433-B48	33MM TAPERED BUTTON BIT 12 DEG.	0,3
7770-5233-B48	33MM TAPERED BUTTON BIT 12 DEG.	0,3
7770-5235-B48	35MM TAPERED BUTTON BIT 12 DEG.	0,4
7770-5433-B48	TAPERED BUTTON BIT 33MM 12 DEG.	0,3
7770-5435-B48	TAPERED BUTTON BIT 35 MM 12 DEG	0,4
7770-9032-42	TAPERED CROSS BIT 32MM 12 DEG	0,4
7770-9045-42	TAPERED CROSS BIT 45MM 12 DEG	0,5
7776-4432-B48	32 MM TAPERED BUTTON BIT 11 DEG.	0,3
7776-4435-B48	35 MM TAPERED BUTTON BIT 11 DEG	0,4
7776-4436-B48	36 MM TAPERED BUTTON BIT 11 DEG	0,2
7776-4438-B48	38 MM TAPERED BUTTON BIT 11 DEG	0,3
7776-4440-B48	TAPERED BUTTON BIT 40MM 11 DEG	0,3
7788-5232-B48	32MM TAPERED BUTTON BIT 7 DEG.	0,3
7788-5233-B48	TAPERED BUTTON BIT 33MM 7 DEG.	0,3
7788-5235-B48	TAPERED BUTTON BIT 35MM 7 DEG.	0,4
7788-5238-B48	TAPERED BUTTON BIT 38MM 7 DEG.	0,4
7795-5232-B48	TAPERED BUTTON BIT 32MM 12 DEG	0,2
7795-5235-B48	TAPERED BUTTON BIT 35MM 12 DEG	0,4
7795-5238-B48	TAPERED BUTTON BIT 38MM 12 DEG	0,3
7795-6428-B48	TAPERED BUTTON BIT 28MM 12 DEG	0,2
7795-6430-B48	TAPERED BUTTON BIT 30MM 12 DEG	0,2
7802-6103-11	SHANK ADAPTER R25 H22X108 L=255MM	1,2
7802-6108-11	SHANK ROD R25 H22X108 L=800MM	2,8
7802-6110-11	SHANK ROD R25 H22X108 L=1000MM	3,4
7802-6124-11	SHANK ROD R25 H22X108 L=2440MM	7,6
7802-6136-11	SHANK ROD R25 H22X108 L=3600MM	11,5
7802-7103-21	SHANK ROD R25 H25X159 L=255MM	1,6
7802-7124-30	SHANK ROD H25-R25 2400 MM	9,5
7802-71373-30	SHANK ROD H25-R25 L=3735 MM	14,0
7802-7567-01	SHANK R25 HLX1/28 D28 L255	1,0
7803-3581-02	SHANK R32 COP1132 D35 L410	2,5
7803-3583-02	SHANK R32 COP1132 D35 L500	3,0

NUMERICAL INDEX WITH WEIGHT TABLE

Item Code	Item Description	Weight (kg)
7803-3590-03	SHANK R32 COP10/1238HD H200 D38 L4	3,8
7803-3652-01	SHANK R32 COP1532/1440/1838 D38 L435	3,6
7803-3656-02	SHANK R32 COP1532/1440/1838	4,2
7803-3704-01	SHANK R32 COP1140/1435 D35 L410	2,6
7803-4703-01	SHANK R32 Hydrastar200 D45 L351	3,7
7803-4725-01	SHANK R32 HC40/HC50 D38 L447	3,3
7803-4726-01	SHANK R32F HC40 D45 L270	2,8
7803-4765-01	SHANK R32F HC50 D45 L270	2,7
7803-4768-01	SHANK R32F HC28 D45 L272	2,7
7803-7500-61	SHANK R32 PR123, URD475/550 D44 L3	3,1
7803-7531-01	SHANK R32 HL500S/510S/B/LH D38L460	3,8
7803-7535-02	SHANK R32 HL500/510 D38 L550	4,2
7803-7547-01	SHANK R32 HL300S D45 L245	2,6
7803-7549-01	SHANK R32 HL300 D32 L400	2,5
7803-7557-01	SHANK R32 HL500/510/510 D45 L550	5,2
7803-7577-02	SHANK R32 HL700/S/LH/PE/650 D52 L6	8,0
7803-7585-01	SHANK R32 HLX5/T D45 L500	5,2
7803-7586-01	SHANK R32 HLX5/T D45 L575	5,4
7803-7661-01	SHANK R32F RD212 D45 L245	2,6
7803-7663-01	SHANK R32F RD314 D45 L205	2,0
7803-7672-01	SHANK R32 RD308/RD314/RD414D38L410	3,2
7804-3590-03	SHANK R38 COP10/1238HD H200 D38 L4	4,3
7804-3652-01	SHANK R38 COP1432/1440/1838 D38 L4	3,9
7804-4725-01	SHANK R38 HC40/HC50 D38 L447	3,8
7804-7531-01	SHANK R38 HL500S/510S/B/LH D38 L46	4,2
7804-7536-01	SHANK R38 HL500S/510S/B/LH D38 L50	4,4
7804-7554-01	SHANK R38 HL550/560, 510T/S D45 L5	5,2
7804-7585-01	SHANK R38 HLX5/T D45 L500	5,3
7804-7658-01	SHANK R38 RD315 D38 L375	3,5
7804-7660-01	SHANK R38 RD212 D38 L379	3,6
7805-6015	SHANK R55L 4050/4052/4053 D56 L500	10,5
7805-7015	SHANK R55R 4050/4052/4053 D56 L500	10,4
7807-6103-11	SHANK ROD R23 H22X108 L=255MM	1,1
7807-6108-11	SHANK ROD R23 H22X108 L=800MM	2,5
7807-6116-11	SHANK ROD R23 H22X108 L=1600MM	5,2
7807-6124-11	SHANK ROD R23 H22X108 L=2400MM	7,7
7807-6132-11	SHANK ROD R23 H22X108 L=3200MM	10,2
7807-6136-11	SHANK ROD R23 H22X108 L=3600MM	12,5
7807-7103-30	SHANK ADAPTER R23 H25X108 L=255MM	1,2
7807-7570-01	SHANK R23 HLX1/28 D28 L235	1,0
7809-7567-01	SHANK R28 HLX1/28 D28 L255	1,2
7821-3232	PILOT ADAPTER A330 12 DEG X 51.5MM	2,4
7821-3440	PILOT ADAPTER R32 12 DEG X 51.5MM	2,7
7821-5440	PILOT ADAPTER R35 12 DEG X 51.5MM	2,7
7821-6740	PILOT ADAPTER A330 12 DEG X 51.5MM	2,7
7822-1526	PILOT ADAPTER R28 6 DEG X 33.5MM	1,9
7822-2526	PILOT ADAPTER R25 6 DEG X 33.5MM	1,3
7822-3526	PILOT ADAPTER R32 6 DEG X 33.5MM	1,5
7823-2647	PILOT ADAPTER T38 12 DEG X 63.1MM	4,6
7832-3301	BIT ADAPTER R25F/R32M	1,2
7833-4301	BIT ADAPTER R32F/R38M	1,8
7833-4401	BIT ADAPTER R32F/T38M	1,9
7839-3301	BIT ADAPTER R28F/R32M	1,4
7852-2309-20	EXTENSION ROD R25 H25 L=915MM	3,6
7852-2312-20	EXTENSION ROD R25 H25 L=1220MM	4,0

NUMERICAL INDEX WITH WEIGHT TABLE

Item Code	Item Description	Weight (kg)
7852-2315-20	EXTENSION ROD R25 H25 L=1525MM	5,7
7852-2318-20	EXTENSION ROD R25 H25 L=1830MM	6,9
7852-2324-20	EXTENSION ROD R25 H25 L=2435MM	9,0
7852-2331-20	EXTENSION ROD R25 H25 L=3050MM	11,3
7852-3112-20	MF ROD R25 H25 L=1220	4,8
7852-313025-20	MF ROD R25-H25 3025 MM	11,9
7852-3137-20	MF ROD R25 H25 L=3660 MM	13,8
7853-2418-20	DRIFTER ROD R32 H25 R25 L=1870MM	6,9
7853-2421-20	DRIFTER ROD R32 H25 R25 L=2175MM	8,5
7853-2424-20	DRIFTER ROD R32 H25 R25 L=2475MM	9,5
7853-2426-20	DRIFTER ROD R32 H25 R25 L=2630MM	10,2
7853-2427-20	DRIFTER ROD R32 H25 R25 L=2785MM	11,0
7853-2429-20	DRIFTER ROD R32 H25 R25 L=2935MM	11,5
7853-2431-20	DRIFTER ROD R32 H25 R25 L=3090MM	12,0
7853-2433-20	DRIFTER ROD R32 H25 R25 L=3340MM	13,1
7853-2437-20	DRIFTER ROD R32 H25 R25 L=3700MM	14,3
7853-3026-20	DRIFTER ROD R32 H28 R25 L=2630MM	12,9
7853-3031-20	DRIFTER ROD R32 H28 R25 L=3090MM	16,0
7853-3037-20	DRIFTER ROD R32-H28-R25 L=3700 MM	19,2
7853-3312-20	EXTENSION ROD R32 R32 L=1220MM	6,4
7853-3315-20	EXTENSION ROD R32 R32 L=1525MM	7,0
7853-3318-20	EXTENSION ROD R32 R32 L=1830MM	9,8
7853-3324-30	EXTENSION ROD R32 R32 L=2435MM	13,1
7853-3331-30	EXTENSION ROD R32 R32 L=3050MM	16,4
7853-3337-30	EXTENSION ROD R32 R32 L=3660MM	19,8
7853-3343-30	EXTENSION ROD R32 R32 L=4265MM	23,1
7853-5109-20	MF ROD R32 R32 L=915MM	5,4
7853-5112-20	MF ROD R32 R32 L=1220MM	7,0
7853-5115-20	MF ROD R32 R32 L=1525MM	8,6
7853-5118-20	MF ROD R32 R32 L=1830MM	10,5
7853-5124-20	MF ROD R32 R32 L=2435MM	13,5
7853-5131-20	MF ROD R32 R32 L=3050MM	16,9
7853-5137-20	MF ROD R32 R32 L=3660MM	20,2
7853-5143-20	MF ROD R32 R32 L=4265MM	23,4
7853-7624-20	DRIFTER ROD R32 H28 R28 L=2475MM	12,0
7853-7626-20	DRIFTER ROD R32 H28 R28 L=2630MM	13,1
7853-7627-20	DRIFTER ROD R32 H28 R28 L=2785MM	13,5
7853-7631-20	DRIFTER ROD R32 H28 R28 L=3090MM	15,4
7853-7633-20	DRIFTER ROD R32 H28 R28 L=3340MM	16,7
7853-7637-20	DRIFTER ROD R32 H28 R28 L=3700MM	18,5
7853-7643-20	DRIFTER ROD R32 H28 R28 L=4305MM	21,5
7854-8631-20	DRIFTER ROD R38 H32 R32 L=3090MM	20,0
7854-8637-20	DRIFTER ROD R38 H32 R32 L=3700MM	23,5
7854-8643-20	DRIFTER ROD R38 H32 R32 L=4305MM	27,0
7854-8649-20	DRIFTER ROD R38 H32 R32 L=4915MM	31,2
7854-9631-20	DRIFTER ROD R38 H35 R32 L=3090MM	23,1
7854-9637-20	DRIFTER ROD R38 H35 R32 L=3700MM	28,7
7854-9643-20	DRIFTER ROD R38 H35 R32 L=4305MM	34,0
7854-9649-20	DRIFTER ROD R38 H35 R32 L=4915MM	38,2
7854-9655-20	DRIFTER ROD R38 H35 R32 L=5525MM	43,0
7857-3208-20	MF ROD R23 H25 L=800MM	3,2
7857-3209-20	MF ROD R23 H25 L=900 MM	3,5
7857-4821-20	MF ROD R23 H22 L=2135MM	6,4
7857-4831-20	MF ROD R23 H22 L=3050MM	9,5
7859-5131-20	MF-ROD R28-ROUND32-R28 L=3050 MM	16,9

NUMERICAL INDEX WITH WEIGHT TABLE

Item Code	Item Description	Weight (kg)
7859-5137-20	MF-ROD R28-ROUND32-R28 L=3660 MM	20,3
7870-1132-11	H22X108 TAPERED ROD HF 12DEG L3200	10,1
7870-1140-11	TAPERED ROD H22 L=4000MM 12 DEG	12,5
7870-1144-11	TAPERED ROD H22 L=4420MM 12 DEG	13,8
7870-1148-11	TAPERED ROD H22 L=4800MM 12 DEG	14,9
7870-1156-11	TAPERED ROD H22 L=5600MM 12 DEG	17,4
7870-1164-11	TAPERED ROD H22 L=6400MM 12 DEG	19,8
7870-1172-11	TAPERED ROD H22 L=7200MM 12 DEG	22,5
7870-1180-11	TAPERED ROD H22 L=8000MM 12 DEG	25,0
7870-6106-11	TAPERED ROD H22 L=610MM 12 DEG	2,2
7870-6112-11	TAPERED ROD H22 L=1220MM 12 DEG	4,0
7870-6118-11	TAPERED ROD H22 L=1830MM 12 DEG	5,9
7870-6120-11	TAPERED ROD H22 L=2000MM 12 DEG	6,4
7870-6124-11	TAPERED ROD H22 L=2440MM 12 DEG	8,0
7870-6131-11	TAPERED ROD H22 L=3050MM 12 DEG	9,6
7870-6132-11	TAPERED ROD H22 L=3200MM 12 DEG	10,1
7870-6137-11	TAPERED ROD H22 L=3660MM 12 DEG	11,5
7870-7143-30	TAPERED ROD H25 L=4300MM 12 DEG	17,0
7876-6106-11	TAPERED ROD H22 L=610MM 11 DEG	2,2
7876-6108-11	TAPERED ROD H22 L=760MM 11 DEG	2,7
7876-6112-11	TAPERED ROD H22 L=1220MM 11 DEG	4,1
7876-6116-11	TAPERED ROD H22 L=1600MM 11 DEG	5,2
7876-6118-11	TAPERED ROD H22 L=1830MM 11 DEG	6,0
7876-6120-11	TAPERED ROD H22 L=2000MM 11 DEG	6,4
7876-6124-11	TAPERED ROD H22 L=2440MM 11 DEG	7,8
7876-6131-11	TAPERED ROD H22 L=3050MM 11 DEG	9,6
7888-6124-11	TAPERED ROD H22 L=2440MM 7 DEG	7,7
7888-6132-11	TAPERED ROD H22 L=3200MM 7 DEG	10,1
7922-6120-11	PILOT ROD L=2000MM 6 DEG	7,0
795-1310	BIT DIAM.WEAR GAUGE 43-51MM BITS	5,8
795-1343	TEMPLATE CROSS/CHIS-INT.CR/XBITS	0,1
795-1397	AUXILIARY TOOL,GRINDING TEMPLATE	0,0
795-1398	AUXILIARY TOOL,GRINDING TEMPLATE	0,0
795-1467	KNOCK-OFF TOOL FOR HEX22	1,0
795-1469	KNOCK-OFF TOOL FOR PILOT ROD	4,8
795-1604A	FISHING SLEEVE R32	1,9
795-1605	FISHING SLEEVE R38	3,9
795-1607A	FISHING SLEEVE T38	4,4
795-1609A	FISHING SLEEVE T51	6,5
795-1613	FISHING SLEEVE T35	2,2
795-1614	FISHING SLEEVE T45	4,1
795-1675	FISHING PIKE T38 FEMALE THREAD	1,2
795-1682	FISHING PIKE T45 FEMALE THREAD	1,6
795-1683	FISHING PIKE T51 FEMALE THREAD	2,2
795-1696	FISHING SLEEVE TUBES ST68, 87 MM	10,9
795-1960	THREAD GREASE 4.5 KG ACINOL 1515	4,5
795-1961	THREAD GREASE 18KG 1515ASC PLASTIC	19,0
795-1962	THREAD GREASE 0,4 KG ACINOL 1515	0,6
795-1963	THREAD GREASE 18KG ACINOL 1405 ASC	18,0
795-1964	THREAD GREASE 240 KG ACINOL 1515	240,0
795-1967	THREAD GREASE 50 KG ACINOL 1515	50,0
795-1969	THREAD GREASE 18KG 1515ASC STEEL	20,3
795-2301-22	AUXILIARY TOOL, CHUCK WEAR GAUGE	0,0
795-2601	FISHING SLEEVE GT60	10,2
795-2604	FISHING PIKE GT60	5,5

